

DISTINCTIVE NASALITY IN KWAWU:
A PROSODIC ACCOUNT

Outi Bat-El
UCLA

Nasality in Kwawu is distinctive in vowels but predictable in consonants. This uncommon distribution is interpreted here in prosodic terms. It is claimed that the feature [+nasal] is represented on morae rather than on individual segments. The assignment of the feature [+nasal] is integrated with syllabification rules, which explains the prosodic characteristics of nasality. Further evidence is drawn from the distribution of nasality in reduplicated forms; the moraic representation of the feature [+nasal] is crucial for the analysis of reduplicated CV stems.

0. Introduction

Kwawu, spoken in the Eastern Region of Ghana, is a dialect of Akan, a member of the Kwa sub-branch of the Niger-Congo Family.¹ This article is concerned with nasality in Kwawu, in particular the correlation between the syllable structure and the distinctive distribution of the feature [nasal] (where distinctive distribution refers to representations prior to local assimilation rules). Like in other dialects of Akan (see Schachter and Fromkin [1968] and Dolphyne [1987]), nasality in Kwawu is distinctive in vowels only, while predictable in consonants. I will argue that this uncommon distribution of nasality can be best accounted for in prosodic terms, and suggest that the feature [+nasal] is underlyingly represented on the mora, from where it percolates to the segments dominated by this mora, while [-nasal] is assigned by default. The direct relation between the syllable structure

¹I wish to thank Mr. Yaw Ntiamoah Agyakwa for his consultant work. Mr. Yaw was born and raised in Obomen, Kwawu, and lived in Kumase, Asante for 4 years.

and nasality is demonstrated by the incorporation of the assignment of nasality with syllabification rules.

Further evidence for this proposal is given by the distribution of nasality in reduplicated forms. Reduplication in Kwawu is roughly a stem copy, with some modification of the copied vowel in monosyllabic stems. Deviation from this generalization is exhibited by Cā stems, where C is oral; in this case the feature [+nasal] is not copied. I will argue on independent grounds that in Kwawu a is underspecified, thus represented by an empty root node, and assume that [+nasal] cannot percolate to an empty node. Reduplication, which does not copy the moraic tier, applies before the empty node is specified and thus before the feature [+nasal] is licenced to percolate. Therefore, the copied segmental material does not include the feature [+nasal].

The article is organized as follows. In section 1 I present the syllable structure in Kwawu, with particular emphasis on CVN syllables (where N stands for a nasal consonant), whose structure is ambiguous amongst languages. I then propose a set of syllabification rules which derive all permissible syllables. In section 2 I examine the distinctive distribution of nasality, and point out the disadvantages of a linear analysis which assumes that the phonemic inventory of the language consists of oral vowels, nasal vowels, and oral (but not nasal) consonants. I will then offer a representation in which the feature [+nasal] is underlyingly specified on the mora. The benefit of this representation is reflected by the direct relation between the syllable structure and the distinctive distribution of nasality. I will show that the distinctive distribution of nasality can be properly incorporated into syllabification rules, which explains its prosodic characteristics. Further evidence for this proposal is given in section 3 where the behaviour of the feature [+nasal] in reduplicated forms is perused. I will show that the peculiar behaviour of nasality in reduplicated forms can be best accounted for under the assumption that [+nasal] is represented on the mora.

1. The Syllable Structure

The syllable structure in Kwawu is a crucial factor in the analysis of the distinctive distribution of nasality proposed here. In section 1.1 I outline the theoretical concepts relevant to my discussion, pointing out the

advantages of the moraic theory for the present analysis (the reader is referred to the references mentioned there for more comprehensive exposition). In section 1.2 I examine the syllable structure in Kwawu, in particular the structure of CVN syllables, which are known to be ambiguous with respect to their moraic structure. I then propose a set of syllabification rules which derive all possible syllable structures.

1.1. Theoretical background. Considerable attention has been given in recent work to the study of the syllable structure, where two fundamentally different structures have been proposed to account for various syllable-sensitive phenomena: the more traditional onset-rhyme structure (see Clements and Keyser [1983] for discussion and references) and the moraic structure (Hyman [1985], McCarthy and Prince [1986], and Hayes [1988]). Both views crucially distinguish between light and heavy syllables, as this contrast has been found to play a major role in phonological processes.

(1) a. The onset-rhyme structure

Light

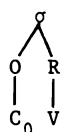

Heavy



σ = syllable
O = onset
R = rhyme
V = vowel
C = consonant

b. The moraic structure

Light

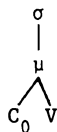

Heavy

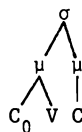

μ = mora

In the onset-rhyme structure a heavy syllable is characterized by complex rhyme, while in the moraic structure a heavy syllable is characterized by two morae. The distinction between the two types of structure relevant to the present discussion rests on the constituent elements in a heavy C_1VC_2 syllable. In the onset-rhyme structure V and C_2 form a constituent ($[C_1[VC_2]]$), while in the moraic structure C_1 and V form a constituent

([[C₁V]C₂]). Nasality in Kwawu provides strong evidence for the moraic syllable structure, since C₁ and V must agree in nasality, while V and C₂ must not. Only in the moraic structure are C₂ and V exclusively dominated by a mora, and as will be argued later on, the mora is the domain of nasality.²

The moraic structure, unlike the onset-rhyme structure, reflects the cross-linguistic distinction between heavy and light CVC syllables. As argued in Hayes [1988], some aspects of the syllable structure are language-specific. In languages whose phonology does not manipulate any weight distinction or treat CVC and CV syllables alike (as opposed to CVV syllables, if any), a CVC syllable is monomoraic. Alternatively, in languages which provide evidence for weight distinction or treat CVV and CVC syllables alike (as opposed to CV syllables), a CVC syllable is bimoraic. A different type of evidence is given here to show that in Kwawu a CVC syllable is bimoraic, but due to dialect interaction some CVC syllables are interpreted as monomoraic for the purpose of one process only.

A somewhat different syllable structure is assumed in McCarthy and Prince [1986] and Hayes [1988], where it is suggested that the prevocalic consonant is not linked to the mora of the first vowel as in (2a), but rather directly to the syllable node, as in (2b):

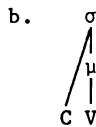
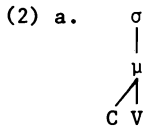

The structure in (2b) is found unsuitable for Kwawu, since the prevocalic consonant and the vowel must form a constituent for the purpose of nasality, therefore both should be dominated by the same mora. I presume that structures (2a) and (2b) are chosen on language-specific grounds, as is the case with postvocalic consonants mentioned earlier, i.e. that in the CVC syllable the final C can be linked to the mora of the vowel, or to an independent mora.

²See Hayes [1988] for a discussion presenting arguments for the advantages of the moraic structure.

The moraic theory neatly accounts for the distinction between short and long vowels and diphthongs. Short vowels and diphthongs are linked to one mora, while long vowels and diphthongs are linked to two morae.

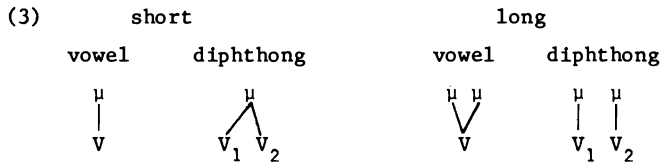

The syllable structure is derived by universal rules subject to language specific constraints. The first rule, as proposed in Hyman [1985], is the Onset Creation rule, which links a consonant to the mora of the following vowel. Hyman assumes that each segment is underlyingly linked to a mora. Therefore, the mora of the prevocalic consonant is deleted. Hayes [1988] raises the problems posited by the assumption that all segments are underlyingly linked to a mora. This representation does not distinguish between high vowels and their corresponding glides. Since high vowels tend to alternate with glides, it has been assumed that glides and vowels have the same melodic features. But if both are underlyingly linked to morae there is no way to distinguish between *u* and *w* or *i* and *y*. Therefore Hayes suggests, following Guerssel [1986], that only vowels are lexically linked to morae, while consonants are free.

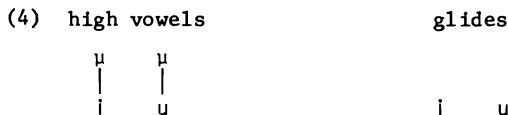

The assumption that vowels are underlyingly linked to morae is crucial to the analysis proposed here, since the mora must be given underlyingly in order to host the feature [+nasal].

Assuming that vowels are underlyingly linked to morae we must then abandon the claim that underlying representations are subject to the Obligatory Contour Principle (OCP), which prohibits identical adjacent (auto) segments. As shown in Janeway [1987], Luganda permits sequences of glides and high vowels, as in *kuwummula* 'rest' and *kusiiyiika* 'scorch'. Three possible

structures can be assumed for these forms, but only one seems appropriate:

(a) If we assume that onsets are linked to the syllable node and that the OCP is in force, the resulting representation (5a) is rather odd. As noted by Janeway [1987:28],

"The oddness of this representation is no argument against it, but it does have implications. First, prosodic well-formedness conditions must be revised to allow ambisyllabic vocalic melodies... Second, this predicts that in a language which has such forms, and also some rule that alters the featural specification of vowels (e.g. $i \rightarrow e / _k$), then the entire melody will undergo this rule."

(b) If we assume that a prevocalic consonant is linked to the mora and the OCP is in force (5b), the underlying representation, would not reflect the correct surface form.

(c) Therefore it is assumed that the prevocalic consonant is linked to the mora and that the OCP is not in force (5c).

(5) a.

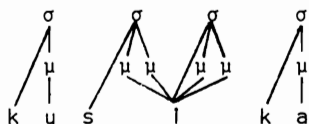

b.

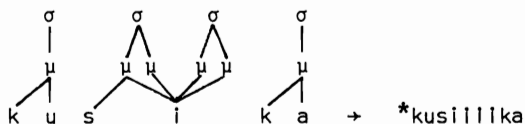

c.

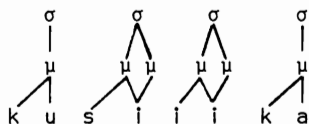

As shown in Odden [1986] OCP violation is not a rare phenomenon, therefore the structure in (5c) is not far-fetched.

The structure of the syllable is mainly rule driven, where partial underlying prosodic structure is often required. The resulting representations consist of three tiers: the syllabic tier, the moraic tier (which is redundant in languages with light syllables only), and the segmental/melodic tier (where segments are short hand for a feature matrix). The advantage of this

representation is that each tier can be independently manipulated by phonological or morphological processes. In addition, as proposed in Clements [1985], Sagey [1986] and others, the feature matrix has an internal hierarchical structure, with an intermediate root node which links the hierarchically organized features to the mora. The exact organization of the features is still controversial. As argued in Archangeli [1984] and Christdas [1988], not all features are underlyingly specified, but here again, the authors do not agree on the degree of underspecification.

1.2. The syllable structure in Kwawu. The following are the surface syllables permitted in Kwawu:

(6) CV	ká	'bite'	píní	'agree'
V	òká	'he bites'	síé	'hide'
N	òká	'not bite'	pám̩	'sewed'
ɾ	fíí	'go out'	páá	'sweep'
VN	òkáká	'he doesn't bite'	tíém	'cry out'
CVN	bám	'embrace'	tìntám	'wrestle'

A VN syllable results from morpheme concatenation (/ɔ+N+kɔ/ → òkókó 'he should go', /tɛ+mu/ → tíém 'cry out'), and it behaves exactly like a CVN syllable. Syllabic ɾ results from vowel deletion before r (/fírí/ → fíí 'go out'), and stems of the surface shape CɾV behave like disyllabic stems. No special consideration will be given to these surface syllables.

The syllabic structure of a stem can be determined on the basis of the verbal tone pattern. Monosyllabic verb stems, typically CV, have high tone (H), while disyllabic verb stems, typically CVCV, have low high tone (LH). CVV stems are disyllabic, since their tone pattern is LH, like that of CVCV stems. CVN stems are monosyllabic since their tone pattern is H, like that of CV stems. The following Verbal Tone rule assigns the H tone, while L is assigned by default:

(7) Verbal Tone

$$\begin{array}{c} \text{H} \\ \vdots \\ [(\sigma) \sigma \end{array}$$

It would be incorrect to state the environment of Verbal Tone as the first syllable from the end since in reduplicated disyllabic verbs, where the copied stem is prefixed, the H tone is also on the second syllable, *kàsákàsà* 'speak'. The L tone at the end of the form is assigned by default. Similarly, in careful speech a L tone is assigned by default to the final consonant in CVN stems.

What is crucial for the ensuing discussion is the structure of the CVN syllable. As noted in section 1.1, the structure of CVC syllables is determined on language-specific grounds, as it can be monomoraic in some languages, and bimoraic in others. In Kwawu a CVN syllable is bimoraic. The argument is based on a vocalization rule, by which a word final nasal velar becomes a high nasal vowel agreeing in rounding and ATR with the preceding vowel.

(8) Nasal Velar Vocalization

$$\left[\begin{array}{l} +\text{cons} \\ +\text{nasal} \\ -\text{labial} \end{array} \right] \rightarrow \left[\begin{array}{l} -\text{cons} \\ \alpha\text{round} \\ \beta\text{ATR} \\ +\text{high} \end{array} \right] / \left[\begin{array}{l} \text{V} \\ \alpha\text{round} \\ \beta\text{ATR} \end{array} \right] _ \#$$

Since Kwawu permits only velar and bilabial nasals in word final position, the feature [-labial] is sufficient to make sure that the rule would not turn final *m* into a vowel. The output of Nasal Velar Vocalization undergoes a Vowel-to-Vowel Nasalization rule, by which a vowel is nasalized when followed by a nasal vowel. Some examples are given below:³

³(1) The evidence for underlying final nasal velar comes from the past tense forms, where the nasal velar surfaces. Past tense is formed by suffixing an empty mora, to which the final segment spreads:

Present	Past	
ká	kàà	'bite'
tóŋ	tòŋ̀	'sell'

The first L tone is derived by a Past Lowering rule, which simply lowers the

(9)	Nasal Velar Vocalization	Vowel-to-Vowel Nasalization	
dɔŋ	→ dɔõ	→ d ^h õ ^h	'to soak'
tɔŋ	→ tɔõ	→ t ^h õ ^h	'to sell'
ɔdaŋ	→ ɔdaĩ	→ ɔ ^h daĩ ^h	'room'
saŋ	→ saĩ	→ s ^h aiĩ ^h	'to return'
bɪŋ	→ bɪĩ	→ b ^h iĩ ^h	'to be hot'
seŋ	→ seĩ	→ s ^h eĩ ^h	'to hang on'
deŋ	→ deĩ	→ d ^h eĩ ^h	'strength'

As mentioned earlier, CVN stems are monosyllabic as their tone pattern is H, like that of CV stems (additional evidence for the monosyllabicity of CVN syllables is drawn from reduplicated forms; see section 3). Now, the question is whether the CVN syllable is monomoraic or bimoraic. If CVN is monomoraic, the output of Nasal Velar Vocalization must be monomoraic as well, and hence CV, where V is a short vowel (in case the vowel in the CVN syllable is high) or a short diphthong (see the structural distinction between short and long vowels and diphthongs in (3) above). Phonetically it is clear that Nasal Velar Vocalization results in a long vowel or a long diphthong, which must be represented by two morae. Therefore, it is concluded that CVN syllables are bimoraic, as it is implausible that Nasal Velar Vocalization would have an effect on the syllable structure, changing monomoraic structure to bimoraic. The process of Nasal Velar Vocalization and Vowel-to-Vowel Nasalization is illustrated below:

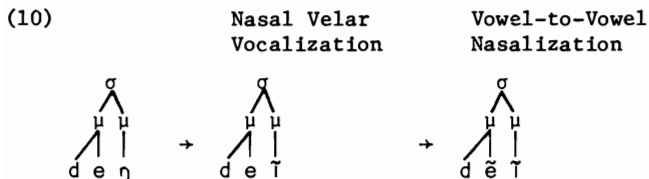

tone of the leftmost syllable in the past tense. The last L tone is assigned by default.

(ii) Vowel-to-Vowel Nasalization is presumably a general rule. There are no vocalic sequences [-nasal][+nasal], but there are [+nasal][-nasal], e.g. mɔ̃á 'gather', as well as [+nasal][+nasal], e.g. múá 'crumple'.

As will be shown in section 3, due to dialectal variation CĀN stems are realized as monomoraic for the purpose of reduplication.

Establishing that the CVN syllable is bimoraic, the following are the possible underlying syllable structures in Kwawu:

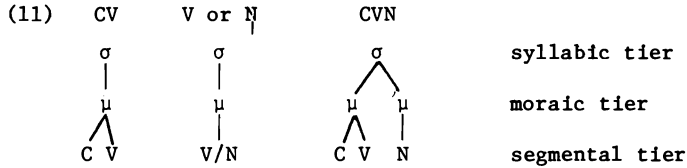

Notice that, as pointed out in Hyman [1985], syllable final nasal and syllabic nasal, which are each the sole element dominated by the mora, contrast only on the syllabic tier. Syllabic nasals are not specified for place features since they always agree in place of articulation with the adjacent consonant. Therefore, in order to distinguish between a syllabic (nasal) consonant and a nasal vowel which constitute syllables, I assume that consonants are specified for the feature [+consonantal].

Given the above underlying syllable structures, the following set of rules is proposed for deriving these structures:

- (12) a. Underlyingly each vowel is linked to a mora, while consonants are free (C stands for unspecified consonant)



- b. Link a free segment to the adjacent mora to the right (non iterative)



- c. Build a syllable on every mora

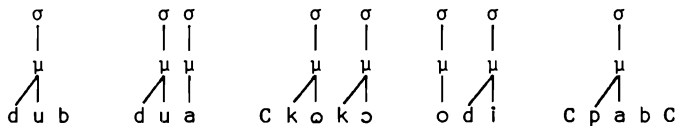

d. Assign a mora to a free segment



e. Link a free mora to the adjacent syllable on the left (non iterative)



f. Build a syllable on each remaining free mora

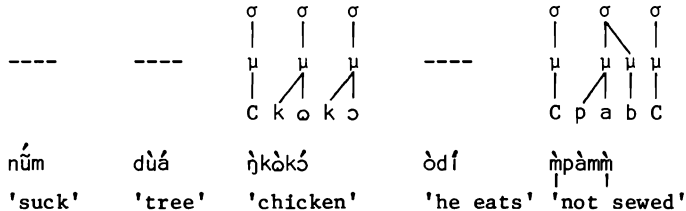

The syllabification rules provided above do not account for the nasal segments. This will be elaborated in the ensuing section, where the assignment of nasality is incorporated in the syllabification rules.

2. The Assignment of the Feature [Nasal]

The distinctive distribution of the feature [nasal] given in section 2.1 below could in principle be analyzed in linear terms, as presented in section 2.2., but this analysis is found inappropriate on universal and language specific grounds. I thus provide in section 2.3 a prosodic account, where it is argued that the feature [+nasal] is represented on the mora. The prosodic characteristic of the feature [nasal] is manifested by a revised version of the syllabification rules proposed in (12) above, with which the assignment of nasality is integrated.

2.1. Descriptive background. The following is the distinctive distribution of nasality in Kwawu:

- (13) a. A nasal consonant must be followed by a nasal vowel

C	V	* C	V
[+nasal]	[+nasal]	[+nasal]	[-nasal]
mǎ́	'give'	*ma	
nǐ́	'his/her'	*nɪ	

- b. An oral voiced consonant must be followed by an oral vowel

* C	V	C	V
[-nasal]	[+nasal]	[-nasal]	[-nasal]
[+voice]		[+voice]	
*bǎ́		bá	'come'
*dǐ́		dí	'eat'

- c. A voiceless consonant can be followed by an oral or nasal vowel

C	V	C	V
[-nasal]	[+nasal]	[-nasal]	[-nasal]
[-voice]		[-voice]	
pǎpǎ́	'palm branch'	pápá	'father'
ètí́	'it scratches'	ètí	'head'

- d. Syllable final consonants must be nasal regardless of the preceding vowel

C	V	C	C	V	C
	[+nasal]	[+nasal]		[-nasal]	[+nasal]
òtǎ́m		'diapers'	òtám		'he wrestles'
tǎ́ŋ		'to leave distance'	tòŋò		'sold'

- e. Kwawu has syllabic nasals, which are confined to the edge of the word

ńtòmǎ́	'cloth'	ńpàmń	'not sewed'
ńwòmǎ́	'book'	ńyí?	'not chew'

Only the distinctive distribution of nasality is given above. Due to various nasal assimilation rules these facts are not always surface true. For instance, the rule of Vowel-to-Vowel Nasalization mentioned in section 1.2 yields a sequence of a voiced consonant followed by a nasal vowel, e.g. deŋ → deĩ (Nasal Velar Vocalization) → dǎ́ĩ (Vowel-to-Vowel Nasalization) 'strength', in violation of (13b). Similarly, surface violation of (13a) is created by a rule of Nasal Assimilation by which a voiced consonant

is nasalized when preceded by a nasal consonant, yielding a nasal consonant followed by an oral vowel (/N+bá/ → ñmá 'not give'). Notice that nasal consonants agree in place of articulation with the adjacent consonant on the right.⁴

The facts given above show dependency in nasality within the mora; a voiced consonant and a vowel dominated by the same mora must agree in nasality. Thus, in a CVN syllable C and V must agree in nasality (if C is voiced), but V and N must not, since N is dominated by an independent mora.

2.2. A linear account. Within a linear account it must be assumed that in Kwawu nasality is distinctive in vowels only, while all consonants are phonemically oral. This line has been taken in Schachter and Fromkin [1968] with respect to other dialects of Akan, and Capo [1983] with respect to Gbe dialects. The following rules are then required for Kwawu under this assumption:

(14) a. Prevocalic Consonant Nasalization

$$C \rightarrow \begin{bmatrix} +\text{nasal} \\ +\text{voice} \end{bmatrix} / \text{ __ } \begin{matrix} V \\ [+nasal] \end{matrix}$$

b. Syllable Final Nasalization⁵

$$C \rightarrow [+nasal] / \text{ __ } \sigma]$$

Rule (14a) accounts for nasal consonants which precede a nasal vowel, e.g. /bǎ/ → mǎ 'give', and rule (14b) accounts for syllabic nasals and syllable final nasals, both in syllable final position, e.g. /Cpáb/ → mpám 'not sew').

⁴But if the nasal consonant is followed by h, the former agrees in place of articulation with the vowel which follows the h; it becomes ŋ when the vowel is back (hŋhám 'wave') and ɲ when the vowel is front (hŋhím 'wave'). As argued in Hayes [1986] and Steriade [1987], h (as well as ?) does not have place features, thus allowing long-distance assimilation.

⁵Rule (14b) could be stated as the following morpheme structure constraint: *[+consonantal -nasal] _σ], i.e. an oral consonant cannot appear at the end of a syllable. This would require the assumption that Kwawu has phonemic nasal consonants, since a constraint does not assign a feature but rather limits its distribution.

This analysis is found undesirable on both universal and language-specific grounds. Universally, there are just a few languages in which nasality is distinctive in vowels only. According to a survey conducted by Cohn [1987], at most 10 out of 164 languages fall into this category. Cohn herself wonders whether "these cases are prosodic in nature, but were described or interpreted by someone who did not consider the possibility of [nasal] playing a role in a domain larger than the segment" [Cohn 1987:17]. This state of affairs is indeed strange, since the generalization about the phonetic distribution of nasality in languages is very different. If a language has nasal vowels it must have nasal consonants, but if a language has nasal consonants it does not necessarily have nasal vowels. Therefore, the assumption that the phonemic inventory of a language consists of nasal vowels but not nasal consonants is unfeasible considering this universal distribution.

From a language-specific point of view, the linear analysis derives the low level nasality on consonants in a rather diverse manner. Prevo-calic consonants get their nasal specification on the basis of segmental structure only, while post vocalic and syllabic consonants get their nasality specification on the basis of syllable structure.

2.3. A prosodic analysis. The prosodic analysis advocated here eliminates this undesirable situation. First, neither vowels nor consonants are phonemically distinguished for nasality, it is rather the mora which exhibits this distinction. The claim is that the feature [+nasal] is represented on the mora, while [-nasal] is assigned by default at a later stage in the derivation. Second, all segments get their nasality specification in a unified way, on the basis of the syllable structure. The feature [+nasal] percolates to all nasal bearing segments dominated by the mora it specifies; the nasal bearing units in Kwawu are voiced consonants and vowels.

It has already been established in the literature that in some languages the feature [nasal] has prosodic characteristics, as it tends to spread over domains larger than the segment, e.g. Guarani [Goldsmith 1976] and Gokana [Hyman 1982]. Like tone, which in some languages is represented on the mora and in others on the syllable, nasality is represented in some language on

the consonant and in others on the mora or a larger unit.⁶

It is thus natural that nasality, being a prosodic feature, is interrelated with other prosodic phenomena, which in this case is the syllable structure. This relation is neatly accounted for by incorporating the assignment of nasality with syllabification rules. As shown below, two of the syllabification rules given in (12) above need to be modified in order to derive the appropriate distribution of the feature [nasal].

- (15) a. (modified) Underlyingly each vowel is linked either to a [+nasal] mora (marked N) or to an unspecified mora, while consonants are free



- b. Link a free segment to the adjacent mora on the right (non iterative)



- c. Build a syllable on every mora

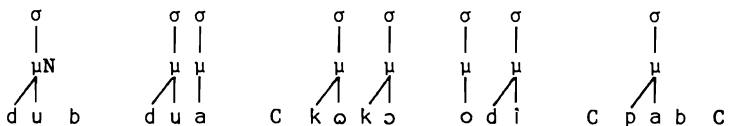

- d. (modified) Assign a [+nasal] mora to a free segment

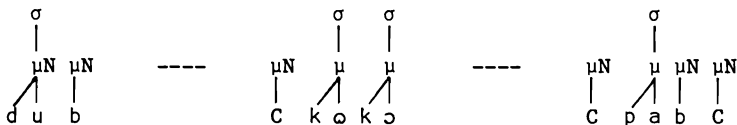

⁶Another way to account for nasal vowels is to assume an abstract representation of monomoraic VN, where V becomes nasal and N is later deleted (see Stahlke [1971] for this view with respect to nasal vowels in Ewe). If this is the case diachronically, it is not implausible that the feature [+nasal] is represented on the mora at a later stage of the language. A similar diachronic process is exhibited by tonogenesis, whereby a segmental distinction at one stage becomes a tonal distinction at a later stage (see Gil [1986] and references there). Thus the syllables CVC₁ and CVC₂ (where C₁ ≠ C₂) become CV^{T1} and CV^{T2} (where T = tone and T1 ≠ T2). Here, as well, the earlier segmental distinction is manifested on a prosodic domain.

- e. Link a free mora to the adjacent syllable on the left (non iterative)



- f. Build a syllable on each remaining free mora



- g. Feature percolation

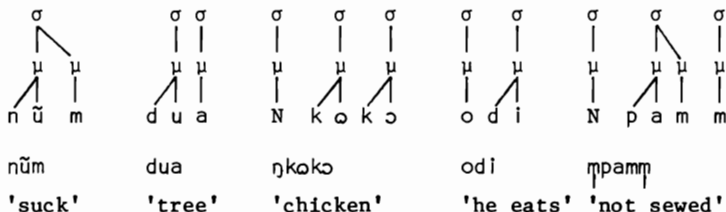

As mentioned earlier, the unspecified nasal consonant (N) agrees in place of articulation with the adjacent consonant.

One may argue that since vowels are lexically linked to morae, the proposal that [+nasal] is lexically specified on the mora is a notational variant to phonemic nasal vowels. An analogical example would be a language with phonemic stress and only monomoraic syllables. Assuming that vowels are lexically linked to a mora, stress would be then lexically specified on the mora. But I doubt that the phonemic inventory of this language could be argued to consist of stressed and stressless vowels, as it is by now well established that stress is a prosodic feature. Nasality in Kwawu is similar to stress in this hypothetical language. Therefore, morae specified for the feature nasal are not notational variants of nasal vowels.

3. Nasality in Reduplicated Forms

Verbs in Kwawu are reduplicated to indicate distributive meaning or multiple object or subject, as in *ká* 'bite' ~ *kíká* 'keep biting', *tón*

'sell' ~ tòntóŋ 'sell to many people'. Disyllabic stems are reduplicated by copying the whole stem as it is; kàsá ~ kàsákàsà 'speak', bɪsá ~ bɪsábɪsà 'ask', tàá ~ tàátàà 'run after', sɪé ~ sɪésɪè 'hide'. Monosyllabic stems are reduplicated by stem copying as well, but here the copied vowel surfaces as high, agreeing in rounding and ATR with the stem vowel.⁷

(16)	ká	kìká	'bite'	
	pé	pìpé	'search'	
	hú	hùhú	'sieve'	
	bó	bòbó	'break'	
	fém	fìmfém	'lend'	
	tám	tìntám	'wrestle'	
	kán	kìŋkán	'read'	[ká̃̀, kìŋká̃̀]
	tóŋ	tòntóŋ	'sell'	[tó̃̀, tòntó̃̀]

Two cases deviate from this generalization:

- a. The copied vowel does not agree in rounding with the stem vowel when the stem vowel is a and the stem initial consonant is /b, p, f, m, kʷ, or sʷ/. Then, the copied vowel is [+round] as in (17a).
- b. The copied vowel does not agree in ATR with the stem vowel when the stem vowel is a and the stem initial consonant is what is termed in Clements [1981] a high consonant (Cʸ). Then, the copied vowel is [+ATR] as in (17b).

(17) a.	fá	fòfá	'take'	
	mã	mòmã	'give'	
	pá	pòpá	'strike'	
	kʷá	kʷòkʷá	'polish'	
	pám	pòm pám	'sew'	(cf. fém fìmfém 'lend')
	bám	bòm bám	'embrace'	
b.	ɕʷá	ɕʷìɕʷá	'peel'	(cf. ɕʷé ɕʷìɕʷé 'look')
	tɕʷá	tɕʷìtɕʷá	'cut'	

⁷Reduplication may reapply to its own output (rarely in disyllabic stems). Reduplicated monosyllabic stems are reduplicated like disyllabic stems, as in (bá →) bóbá ~ bóbábóbà 'come'.

ɕʷám	ɕʷíɕʷám	'pull away'
sʷá	sʷísʷá	'be small'

The contrast between mono- and disyllabic stems is manifested by the copied vowel. The question is then what information is to be specified in the reduplication rule to account for this distinction. In the spirit of Marantz [1982], reduplication is viewed here as affixation of a prosodic unit unspecified for segmental material. I uphold however McCarthy and Prince's [1986] idea that the affixed unit is not composed of timing units (C- and V-slots) as proposed by Marantz, but rather of prosodic units (mora, syllable, etc.). The segmental material is later copied from the base stem and associated with the affixed prosodic unit. The distinction between mono- and disyllabic reduplication lies on the copied prosodic unit; only monosyllabic prefixes are prespecified for the feature [+high], which takes precedence over any contradicting feature contributed by the stem.

The first stage of reduplication is copying the syllabic tier of the stem and placing it on the left of the base.

(18) Syllabic tier copying



The difference between mono- and disyllabic reduplicated stems falls at the succeeding stage, where the feature [+high] is linked to a monosyllabic prefix only. By convention, the intermediate prosodic structure (in this case the mora) is automatically set, to link between the feature and the syllable.

(19) Prespecification of [+high] to monosyllabic prefix

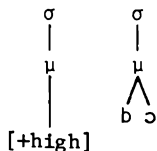

The next stage is to copy the stem and to link it to the prefixed syllable(s):

(20) Stem copying

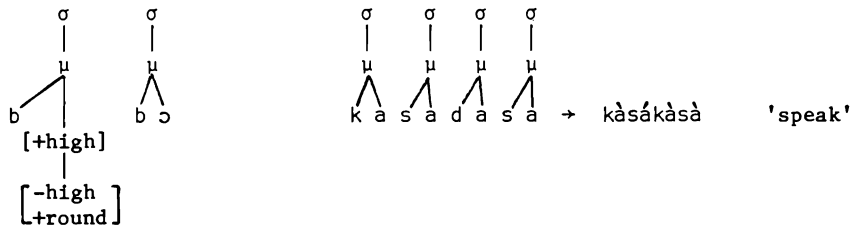

Since the features [+high] and [-high] contradict each other, the feature [-high] is deleted, giving precedence to the prespecified feature. [-ATR] is assigned by default.

(21)

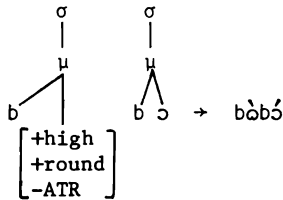

Reduplication in Kwawu is basically stem copying, but it applies in two stages: (i) copy the syllabic tier, and (ii) copy the segmental tier. A specific rule which applies between the two stages, linking the feature [+high] to monosyllabic prefixes, is responsible for the surface distinction between mono- and disyllabic reduplicated stems. Notice that CVN stems, being monosyllabic, are reduplicated like CV stems, regardless of the number of morae.

underspecification: Relevant to the present discussion is the behavior of monosyllabic stems with a (hereafter a-stems) with respect to rounding. As mentioned earlier, in reduplicated a-stems the copied vowel is [+round] if the stem initial consonant is a nonpalatal labial or is labialised (b, p, f, m, s^h, k^w) and [-round] elsewhere (also in the environment of labialised palatals like t^h and ɸ^h). This situation can be well accounted for assuming that a is underspecified and is thus represented by a mora linked to an empty root node. The notion of underspecification is discussed in length in Archangeli [1984] and Christdas [1988] where it has been argued that seg-

ments are not fully specified in the underlying representation. In Kwawu, as I will show below, there is strong evidence for underspecifying *a*, which yields the following feature matrix of vowels ([ATR] is omitted):

(22)

	i	u	e	o	a
high	+	+	-	-	-
round	-	-	-	-	-

The feature [round] must be specified for its two values in order to distinguish between reduplicated *a*-stems, where the vowel does not contribute a value for [round] to the copied material, and *e/i*-stems, where the copied vowel is always [-round] (cf. *pám pám* 'sew' vs. *fém fém* 'lend'). As for [high], McCarthy and Prince [1986] argue that this feature is specified for its negative value only. I find this representation inappropriate since there are consonants in Kwawu which must be underlyingly specified for secondary articulation [+high], and it is implausible that [+high] in consonants is different from [+high] in vowels (I will return to the analysis of McCarthy and Prince at the end of this section).

After reduplication, the feature [+labial] spreads from a [+labial] non-palatal consonant to the following vowel, as formulated below (° stands for a root node):

(23) Labial Spreading

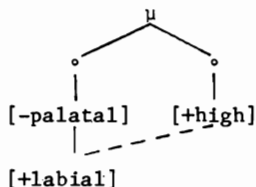

I assume that the feature [+labial] is realized as [+round] when linked to vowels. Labial Spreading applies after the segmental material is copied, such that it does not affect the stem *a*; the feature [+high] is thus crucial in the structural description. Notice that Labial Spreading is a fill-in rule, rather than feature-changing rule and therefore does not affect high vowels which are already specified for the feature round. Thus, *fí ~ fífí*

'go out' would not become *f^ó ~ f^òf^ó. Nor would it affect the copied vowel in e-stems since e contributes its [-round] feature to the copied vowel. Thus, fém f^lɛfém 'lend' would not become *f^òɛfém.

The following default rules then apply to fill in the missing features:

$$(24) \text{ a. } [\alpha\text{back}] \rightarrow / \left[\begin{array}{c} \text{---} \\ \alpha\text{round} \end{array} \right]$$

$$\text{b. } \begin{array}{c} \text{u} \\ | \\ \circ \end{array} \rightarrow \left[\begin{array}{c} +\text{low} \\ +\text{back} \\ -\text{round} \\ -\text{ATR} \end{array} \right]$$

Rule (24a) fills in the value for [back], which is later required for the Nasal Assimilation rule across h (see footnote 4). Rule (24b) fully specifies the features for a.⁸

It is worth mentioning the advantage of a complete underspecified a regarding [ATR]. As argued in Clements [1981] [+ATR] is specified on stems while [-ATR] is assigned by default, with the exception of a, which is underlyingly specified for [-ATR]. That is, not only is a the single vowel specified for this feature, it is also specified for the default value. A complete underspecification of a eliminates this cumbersome representation, assuming that vowel harmony applies after a gets its features via rule (24b). This is not a remote assumption since vowel harmony affects the verbal clitics, which indicates its late application.

Recall also that in cases where the stem vowel is a and the stem initial consonant is CV, the copied vowel is always [+ATR], regardless of the stem vowel. We must therefore assume a minor rule which links the feature [+ATR] to a root node specified for [+high] only when preceded by this particular class of consonants. Notice that here again, in order to distinguish

⁸These rules are not crucially ordered. If (24a) applies first, it fails to assign a value for [back] to the empty root node in the absence of the feature [round]. If (24a) applies second, it does not affect the feature matrix of a, filled in by rule (24b), since it is a feature-filling rule and not a feature-changing rule.

between $\varphi^4\acute{a} \sim \varphi^4\varphi^4\acute{a}$ 'peel' and $\varphi^4\acute{e} \sim \varphi^4\varphi^4\acute{e}$ 'look', where only in the former the copied vowel is [+ATR], we must assume that *a* is underspecified. Otherwise the copied vowel would be [+high -round] in both cases, and there would be no way to account for the fact that [+ATR] is linked only when the stem vowel is *a*.

The process of reduplication of *a*-stems is illustrated below for $b\acute{a} \sim b\acute{o}b\acute{a}$ 'come' (irrelevant features of *b* are omitted for simplicity):

- (25) a. Reduplication (syllabic tier copying, high specification, segmental tier copying)

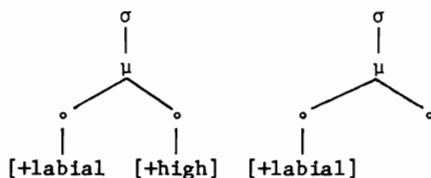

- b. Labial Spreading (23)

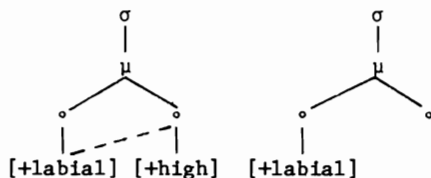

interpreted as

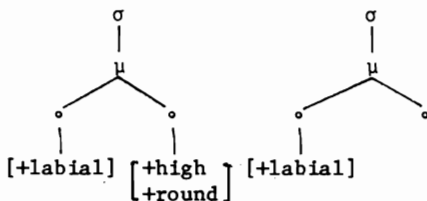

- c. Default rule (24b)

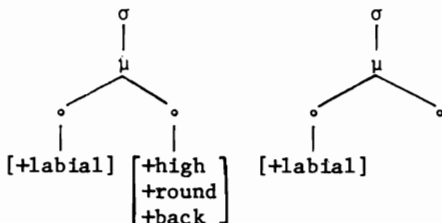

d. Default rule (24b)

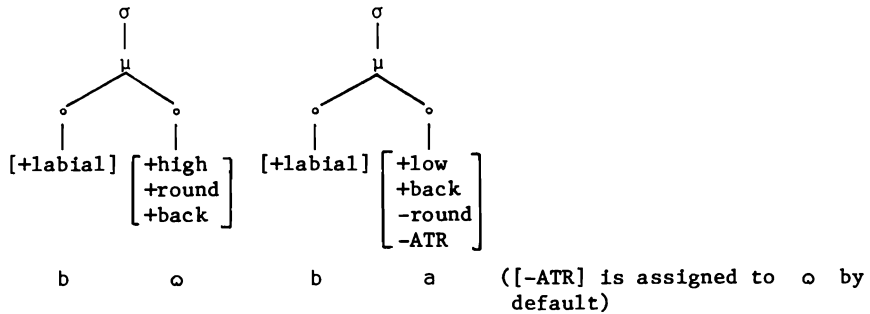

In stems where Labial Spreading does not apply, e.g. *ká* ~ *kìkà* 'bite', the negative value for [round] is assigned by default.

Thus, in order to account for the peculiar behaviour of a-stems it has been assumed that *a* is underspecified. Labial Spreading, which spreads the feature [+labial] from the stem initial non-palatal labial or labialized consonant to the following [+high] vowel is responsible for the feature [+round] (and consequently [+back]).

reduplication and nasality: The underspecification of *a* is a crucial factor in the distribution of nasality in reduplicated a-stems. In disyllabic stems nasality is copied along with the other features, e.g. *kìsá* ~ *kìsákìsà* 'turn over'. In monosyllabic stems the situation is more complicated as can be seen from the data below:

- (26) a. *ká* *kìká* 'say'
 sá *sìsá* 'change'
- b. *tí* *títí* 'scratch'
 hú *húhú* 'see'
- c. *má* *mómá* 'give'
 ná *níná* 'find'
- d. *fám* *fómfám* 'embrace'
 sóm *sónsóm* 'worship'

The generalizations to be drawn from the above data are as follows:

- a. In a $C\tilde{V}$ stem (C is oral) where \tilde{V} is [-high] (thus must be a),⁹ the copied vowel is oral.
- b. In a $C\tilde{V}$ stem where \tilde{V} is [+high], the copied vowel is nasal.
- c. In a $N\tilde{V}(N)$ stem, the copied vowel is always nasal (regardless of vowel height).
- d. In a $C\tilde{V}N$ stem, the copied vowel is always nasal (regardless of vowel height).

Following the assumption that a is underspecified (thus represented by an empty root node linked to a mora), my claim is that the feature [+nasal] fails to percolate from the mora to the empty root node. That is, [+nasal] cannot be the sole feature dominated by a node (recall that syllabic nasals are specified for [+consonantal], thus they license percolation). When reduplication applies, the feature [+nasal] is still located on the mora, therefore not copied along with the segmental tier. Later on, when the empty root node receives the features for a via rule (24b), the feature [+nasal] percolates, as it must eventually end up on the segmental tier. Recall that reduplication involves copying of the syllabic and the segmental tiers, but not the moraic tier. Therefore, the feature [+nasal] cannot be copied if it is still located on the mora. This explains why in reduplicated $C\tilde{V}$ stems, which consist of an oral consonant and a low nasal vowel, the copied vowel is oral.

In $N\tilde{a}$ stems the feature [+nasal] does percolate, as there is a specified nasal bearing unit dominated by the mora, i.e. the consonant. It is thus assumed that [+nasal] can be the sole feature dominated by a root node only if it is doubly-linked, and the second root node is specified for other features.¹⁰ That is, the representation in (27a) is ill-formed while that in (27b) is acceptable:

⁹There are no phonemic mid nasal vowels in Kwawu. The only source of mid nasal vowels is the rule of Vowel-to-Vowel Nasalization mentioned in section 1.2, whereby a vowel is nasalized when followed by a nasal vowel.

¹⁰Similar restrictions are discussed in Itô [1986]. In Italian, for example, obstruents (other than s) can appear in coda position only if they are doubly-linked, e.g. labbro 'lip' but *apbro. The syllable structure is (C)CVC.

- (27) a. b.

I assume that the representation is exhaustive, that is, features which are not specified are not there. Thus in (27a) the root node is specified for [+nasal] only, and therefore the representation is ill-formed. In (27b) the feature [+nasal] is doubly-linked, which licenses one empty root node.

The behavior of CǎN stems does not conform with the above analysis, I believe for historical reasons. On the basis of the analysis provided above the prediction is that the copied vowel in CǎN stems is oral, as it is the case with Cǎ stems; but this is wrong (see data in (26d)). The problem is that CǎN stems are reduplicated as if they were monomoraic, i.e. ǎ and N are dominated by the same mora, as in Nǎ stems. This is evident from the copied nasal vowel.

As described in Dolphyne [1987] for other dialects of Akan, many CVN stems are historically derived from CVNV stems. This actually explains the bimoraic structure of CVN stems at the current stage of the language: a disyllabic bimoraic stem became monosyllabic without effect on the moraic structure. The relevant details are as follows:

- (i) C V N V > C ǎ N (ii) C V N V > C V N
 [+high] [+high] [-high] [-high]

The nasalization of a high vowel preceding a nasal consonant is a synchronic rule in Kwawu (as well as in some other dialects of Akan). The evidence comes from surface forms like bũm 'bark' whose underlying forms must be bum in accordance with the generalization given in (13b) that an oral voiced consonant must be followed by an oral vowel.

These are the cases which do not cause any problems. CVN stems, where V is oral, are underlyingly represented as bimoraic, as has been argued earlier and also in accordance with the historical facts. CǎN stems, where ǎ is high, are underlyingly bimoraic CVN stems. High Vowel Nasalization precedes reduplication, as is evident from pairs like (kúm →) kúm ~ kũŋkúm 'kill', tóŋ (tǎŋ) ~ tǎntóŋ (tǎntǎŋ) 'sell'. If High Vowel Nasalization followed reduplication, we would expect *tǎntóŋ.

The problem is then limited to CĀN stems, which are historically monomoraic. Otherwise we would not expect the vowel to be nasal (recall that CaNV > CaN and not CĀN). In general, historical considerations cannot provide evidence for synchronic analysis, since native speakers (at least infants and uneducated adults) do not have knowledge of the history of their language. But in this particular case the historical evidence is reflected in the neighboring dialects, and all dialects of Akan are mutually intelligible. The dialects which optionally preserve the final vowel are Asante and Akuapem, and surprisingly enough Mr. Yaw, who provided the data for this paper, is a fluent speaker of Asante (but a native speaker of Kwawu—see footnote 1). It is very possible then that in order to solve some surface irregularities, speakers search for a clue in another dialect.

My claim is that CaN stems are interpreted as bimoraic since they correspond to disyllabic stems in other dialects (and those which do not correspond to bisyllabic stems are regularized). CĀN cannot correspond to disyllabic stems since the vowel is nasal and is therefore interpreted as monomoraic with respect to reduplication. This explains why the copied vowel in reduplicated CĀN stems is nasal. As in Nā stems, [+nasal] is licensed to percolate since there is at least one specified root node which can dominate it, i.e. the syllable final consonant.

Notice, however, that this interpretation does not hold for Nasal Velar Vocalization (8), where all CVN syllables behave alike, i.e. as bimoraic. This is clearly reflected by the minimal pair t̀nt́áŋ (t́áŋ) 'dislike' ~ t̀nt́áŋ (t́áŋ) 'leave distance', which after Nasal Velar Vocalization becomes t̀nt́ǎĩ ~ t̀nt́ǎĩ̃. The distinction between t́áŋ and t́ǎŋ is lost after Nasal Velar Vocalization, resulting in t́ǎĩ̃, since they are both treated as bimoraic. But for the purpose of reduplication t́ǎŋ is interpreted as monomoraic.

The cumbersome solution I suggest reflects the inconsistency of the language, which results from historical change. It is possible that there is an additional syllabification rule which merges two [+nasal] morae dominated by the same syllable:

(28)

$$\begin{array}{c} \sigma \\ \swarrow \quad \searrow \\ \mu N \quad \mu N \end{array} \rightarrow \begin{array}{c} \sigma \\ | \\ \mu N \end{array}$$

This representation is appropriate for feature percolation and reduplication. High Vowel Nasalization applies after reduplication. Therefore, we must assume that (28) is undone before this rule. Informally, all CVN stems are treated alike, i.e. as bimoraic, for the purpose of High Vowel Nasalization.

Another problem arises with disyllabic stems, where \tilde{a} is copied as it is, e.g. $kis\tilde{a} \sim kis\tilde{a}kis\tilde{a}$ 'turn over' ($*kisakis\tilde{a}$). To reconcile this discrepancy I assume that reduplicated disyllabic stems are subject to the Identity Constraint proposed in Wilbur [1973], which accounts for the tendency to preserve the identity between the stem and the copied material. In Tagalog for example, there is a Nasal Assimilation rule ($maŋ+bigay \rightarrow mamigay$ 'give (Modal)') and a reduplication rule which copies the first CV of the stem ($sulat \sim susulat$ 'write (Future)'). Since reduplication applies before the prefix $maŋ-$ is attached, the expected prefixed reduplicated form of $maŋ+bi+bigay$ is $*mamibigay$, where only the first b , i.e. the copied one, is affected by Nasal Assimilation. The actual form is however $mamimigay$ 'give (Future)', where both b 's are nasalized (although only the first one is preceded by a nasal consonant) in accordance with the Identity Constraint. Similarly in Kwawu, since in most disyllabic reduplicated stems the copied material is identical to the base, disyllabic stems with \tilde{a} are regularized.

I turn now to the analysis of reduplication of other dialects of Akan presented in McCarthy and Prince [1986]. I abstract away from irrelevant disagreements which are due to dialectal variation.¹¹ Prespecification has

¹¹McCarthy and Prince argue that the mora is the relevant unit for reduplication. In their data CVN stems are either monomoraic or bimoraic, as some are reduplicated as monomoraic, i.e. monosyllabic, and others as bimoraic, i.e. disyllabic. In Kwawu all CVN stems are reduplicated as monosyllabic. So the minimal pair $pam \sim pampam$ (bimoraic) 'drive out' vs. $pam \sim pimpam$ (monomoraic) 'sew' does not appear in Kwawu. The reduplicated form of both is $p\grave{o}mp\acute{a}m$. Similarly, $dan \sim dandan$ (bimoraic) 'turn' appears in Kwawu as a disyllabic stem $dan\tilde{}$, thus reduplicated $dan\tilde{d}an\tilde{}$.

been rejected by McCarthy and Prince mainly because it allows a wide range of possibilities which are not attested. For instance, McCarthy and Prince note that *r*, or probably consonants in general, are never found as the prespecified element. I believe that the absence of prespecified consonants (or consonantal features) lies in the ill-formedness of a structure in which a prosodic unit, mora or syllable, is linked to a consonant. Since the affixed material in reduplication is prosodic in nature, and does not consist of segmental positions (C- and V- slots), the prespecified element must be a potential syllabic nucleus. Indeed, languages which permit syllabic consonants should in principle allow reduplicated affixes with prespecified consonants (only those which participate as syllabic in the language). But this situation does not arise since consonants are not topical syllabic nuclei, as they gain this property via the prosodic structure, and may lose it when prespecified at the stage which the rest of the stem is copied.

The alternative solution proposed by McCarthy and Prince, which abolishes prespecification, is that in monosyllabic stems only part of the segmental material is copied. Assuming that vowels are specified for [\pm round], [$-$ low], and [$-$ high], only [round] and [low] are copied; [+high] is assigned later by default to the copied vowel.

The major problem with the assumption that [+high] is a default feature lies in consonants which must be underlyingly specified for the secondary articulation [+high]. Consider Kwawu's phonemic inventory:

(28)	Labial	Alveolar	Palatal	Velar
Stops	p b	t d		k g
labialized				k ^w
Affricates			tʃ dz	
labialized			tʃ ^w dz ^w	
Fricatives	f	s	ʃ	
palatalized		s ^y		
labialized			ʃ ^w	
labiopatalized		s ^h		
Liquids & Glides		r	y	w

As argued in Keating [1988], palatals are complex segments, i.e. they involve double articulation, one of which is [+high]. In addition, in order to distinguish between *s* and *sʷ* the feature [+high] must be available. It is not to claim that vowels and consonants share the same features, but rather that consonants may have a secondary articulator, which is a vocalic feature. It would be far-fetched to believe that a secondary articulator [F] on consonants is not the same as the primary articulator [F] in vowels, especially in the presence of consonant - vowel assimilation rules, as Labial Spreading (23) and Nasal Assimilation (footnote 4). Therefore [+high] cannot be underspecified in Kwawu, which subsequently requires that monosyllabic reduplicated prefixes must be assigned a [+high] feature prior to copying the melodic material.

Another argument against the analysis presented by McCarthy and Prince is the feature geometry they assume. Given the underlying features [round], [low], and [high], they propose that only [round] and [low] are copied in monomoraic reduplication (while all the features are copied in bimoraic reduplication). Therefore they suggest that [round] and [low] are grouped together separate from [high]. This classification is rather odd since one would expect height features, i.e. [low] and [high], to be grouped together.

Empirical evidence against this proposal for Kwawu rests on the behavior of *a* with respect to rounding. Under this account there would be no explanation why Labial Spreading affects the copied vowel of *pám* 'sew' (*pòm pá m*) but not of *fém* 'lend' (*fì m fém*), if it applies after [+high] is assigned by default. If Labial Spreading applies before [+high] is assigned, there is no explanation why the *a* of the stem is not affected. I thus conclude that McCarthy and Prince's analysis is not compatible with Kwawu data.

4. Conclusion

The account of distribution of nasality suggested here centers on the view that features are not necessarily represented on the segmental node in the underlying representation. This view is adopted from several studies which propose units larger than the segment as feature bearers, in order to account for the surface distribution of this feature within a domain larger

than the segment.

This, indeed, is not the immediate conclusion which comes to mind when observing the distribution of nasality in Kwawu, since its domain is a small prosodic unit. But I believe that the arguments set forth do demand the proposed conclusion. It has been shown that the alternative linear analysis does not coincide with universal observations, and it seems rather odd from a language specific point of view.

In addition, the behavior of nasality in reduplicated forms provides a strong support for the representation of the feature [+nasal] on the mora. Since the mora is not involved in reduplication, the feature [+nasal] is not copied when it fails to percolate.

REFERENCES

- Archangeli, Diana B. 1984. "Underspecification in Yawelmani phonology and morphology." Ph.D. dissertation, MIT.
- Capo, Hounkpatin C. 1983. "Nasal vowels and nasalized consonants in Gbe." In I.R. Dihoff (ed.), *Current Approaches to African Linguistics* v.1., pp. 127-143. Dordrecht: Foris Publications.
- Clements, George N. 1981. "Akan vowel harmony: a nonlinear analysis." In G.N. Clements (ed.), *Harvard Studies in Phonology*, v. 2, pp. 108-177. Bloomington, IN: Indiana University Linguistics Club.
- Clements, George N. 1985. "The geometry of phonological features." In G. Ewen and J. Anderson (eds.), *Phonology Yearbook 2*, pp. 225-252. Cambridge: Cambridge University Press.
- Clements, George N. and Samuel J. Keyser. 1983. *CV Phonology: a Generative Theory of the Syllable*. Cambridge, MA: MIT Press.
- Christdas, Prathima. 1988. "The phonology and morphology of Tamil." Ph.D. dissertation, Cornell University.
- Cohn, Abigail C. 1987. "A survey of the phonology of the feature [+nasal]." Ms., UCLA.
- Dolphyne, Florence A. 1987. *The Akan Twi-Fante Languages: its Sound System and Tonal Structure*. Legon: University of Ghana Press.
- Gil, David. 1986. "A prosodic typology of language." *Folia Linguistica* 20: 165-231.

- Goldsmith, John A. 1976. "Autosegmental phonology." Ph.D. dissertation, MIT.
- Guerssel, Mohamed. 1986. "Glides in Berber and syllabicity." *Linguistic Inquiry* 17:1-12.
- Hayes, Bruce. 1986. "Assimilation as spreading in Toba Batak." *Linguistic Inquiry* 17:467-500.
- Hayes, Bruce. 1988. "Compensatory lengthening in Moraic Theory." Ms., UCLA.
- Hyman, Larry M. 1982. "The representation of nasality in Gokana." In H. van der Hulst and N. Smith (eds.), *The Structure of Phonological Representation* (part I), pp. 111-130. Dordrecht: Foris Publications.
- Hyman, Larry M. 1985. *A Theory of Phonological Weight*. Dordrecht: Foris Publications.
- Itô, Junko. 1986. "Syllable theory in prosodic phonology." Ph.D. dissertation, University of Massachusetts, Amherst.
- Janeway, Roger. 1987. "Luganda in Moraic Theory." Ms., UCLA.
- Keating, Patricia A. 1988. "Palatals and complex segments: X-ray evidence." In *UCLA Working Papers in Phonetics* v. 69, pp. 77-91. Los Angeles: UCLA Department of Linguistics.
- Marantz, Alec. 1982. "Rereduplication." *Linguistic Inquiry* 13:435-482.
- McCarthy, John J. and Alan S. Prince. 1986. "Prosodic morphology." Ms., University of Massachusetts, Amherst, and Brandeis University.
- Odden, David. 1986. "The role of the obligatory contour principle in phonological theory." *Language* 62:353-383.
- Sagey, Elizabeth C. 1986. "The representation of features and relations in non-linear phonology." Ph.D. dissertation, MIT.
- Schachter, Paul and Victoria Fromkin. 1968. *A Phonology of Akan: Akuapem, Asante & Fante*. Working Papers in Phonetics, 9. Los Angeles: UCLA Department of Linguistics.
- Stahlke, Herbert F.W. 1971. "Topics in Ewe phonology." Ph.D. dissertation, UCLA.
- Steriade, Donca. 1987. "Locality conditions and feature geometry." In J. McDonough and B. Plunkett (eds.), *Proceedings of NELS*, 17, pp. 595-617. Amherst: University of Massachusetts.
- Wilbur, Ronnie B. 1973. "The phonology of reduplication." Bloomington, IN: Indiana University Linguistics Club.

