

Flight propensity of isofemale lines of *Trichogramma pretiosum* Riley in two relative humidity levels

Aloisio Coelho Jr^{1,*}, Richard Stouthamer², and José Roberto Postali Parra¹

Abstract

This study evaluated the flight propensity of 6 isofemale lines of *Trichogramma pretiosum* Riley (Hymenoptera: Trichogrammatidae) using a flight test developed as a quality control measure for mass reared *Trichogramma* wasps. The same isofemale lines were used in earlier work to determine fecundity in the laboratory and performance in the field. We used 5 isofemale lines from a Mediterranean climate, collected in Irvine, California, USA, and 1 isofemale line from a humid subtropical climate, collected in Piracicaba, São Paulo, Brazil. The flight propensity was assessed with a short-range flight test of the different isofemale lines at 2 different relative humidity levels, 80% and 30%. Relative humidity (RH) affected only the isofemale line from Piracicaba, and about 30% fewer insects flew in high RH conditions compared with low RH conditions. Relative humidity conditions did not affect the California isofemale lines, which showed a flight propensity above 75% in both RH conditions. These results showed that for some lines, environmental conditions at the release sites might adversely affect the flight propensity. However, just the flight test method was not sensitive enough to discriminate the lines with different field performances.

Key Words: Quality control; flight test; biological control; IPM

Resumen

Este estudio evaluó la propensión al vuelo de seis líneas isohembras de *Trichogramma pretiosum* Riley, utilizando una prueba de vuelo desarrollada como medida de control de calidad para las avispas *Trichogramma* criadas en masa. Se utilizaron las mismas líneas isohembras en un trabajo anterior para determinar su fecundidad en el laboratorio y su desempeño en el campo. Utilizamos cinco líneas isohembras de clima mediterráneo, recolectadas en Piracicaba, São Paulo, Brasil. Se evaluó la propensión al vuelo con una prueba de vuelo de corto alcance de las diferentes líneas isohembras bajo una humedad relativa (HR) del 80% y 30%. La HR solo afectó a la línea isohembra de Piracicaba y aproximadamente un 30% más de insectos no volaron en condiciones de baja HR. Las condiciones de HR no afectaron las líneas isohembras de California, que mostraron una propensión de vuelo superior al 75% en ambas condiciones de humedad relativa. Estos resultados mostraron que en algunas líneas, las condiciones ambientales en los sitios de liberación podrían afectar negativamente la propensión a volar de los insectos. Sin embargo, la prueba de vuelo por sí sola no fue lo suficientemente sensible como para discriminar las líneas con diferentes actuaciones en el campo.

Palabras clave: control de calidad; prueba de vuelo; control biológico; IPM; humedad

Egg parasitoids of the genus *Trichogramma* (Hymenoptera: Trichogrammatidae) are the natural enemies that are most commonly used to control lepidopteran pests (Wajnberg & Hassan 1994; Parra & Zucchi 1997; Cônsoli et al. 2010). In the former Soviet Union, 17 million ha of various agricultural crops were treated with species of *Trichogramma* for pest control (Filippov 1992). In Brazil, approximately 500,000 ha of sugarcane were treated with *Trichogramma galloi* Zucchi to control *Diatraea saccharalis* Fab. (Lepidoptera: Crambidae), using 3 releases per ha. *Trichogramma pretiosum* Riley also is used in large areas to control *Chrysodeixis includens* Walker (Lepidoptera: Noctuidae) and *Helicoverpa armigera* Hübner (Lepidoptera: Noctuidae) in soybean, and in smaller areas of bean, tomato, avocado, and cotton (Parra et al. 2015). One factor that is responsible for the success of *Trichogramma* as a biological control agent is the ease with which this insect can be mass reared using factitious hosts (Flanders 1927; Parra 2010). Globally, public and private enterprises commercially rear *Trichogramma*; however, for the success of biolog-

ical control programs using these parasitoids, the insects must meet minimum quality requirements, especially under field conditions (van Lenteren 2003).

Dutton and Bigler (1995) suggested that the flight propensity of *Trichogramma* is an important feature for their success in biological control programs, as the initial dispersal and foraging of the parasitoids in the field are directly related to their capacity to disperse from the release points. To measure the short-range flight propensity, a flight-test unit was developed to evaluate this quality parameter under laboratory conditions (Dutton & Bigler 1995). According to van Lenteren (2003), this flight test was adopted as a standard by the International Organization for Biological Control (IOBC). *Trichogramma* strains differ in many of their biological parameters; among others, their flight propensity in the field and laboratory (Cerutti & Bigler 1995), reproductive performance in the field and laboratory (Sorati et al. 1996; Thomson & Hoffmann 2002; Guzmán-Larralde et al. 2014), and parasitism and dispersal capacity in field conditions (Bourchier & Smith 1996; Dutton et

¹Escola Superior de Agricultura "Luiz de Queiroz" – ESALQ, Laboratory of Insect Biology, Department of Entomology and Acarology, Piracicaba, São Paulo, 13400-970, Brazil; E-mail: aloisiocoelho@usp.br (A. C.); jrpparra@usp.br (J. R. P. P.)

²University of California Riverside, Department of Entomology, Riverside, California 92521, USA; E-mail: richards@ucr.edu (R. S.)

*Corresponding author; E-mail: aloisiocoelho@usp.br

Supplementary material for this article in Florida Entomologist 101(1) (June 2018) is online at <http://purl.fcla.edu/fcla/entomologist/browse>

al. 1996; Fournier & Boivin 2000; Coelho Jr. et al. 2016). Little is known about the effect of environmental factors on the flight propensity of *Trichogramma* and its variation within species.

This study evaluated the flight propensity of 6 isofemale lines of *T. pretiosum* under 2 different relative humidity levels (80% and 30%). These lines, which are known to differ in other life history traits, especially their parasitism capacity in field conditions, were initiated with specimens collected from areas with different climatic conditions.

Material and Methods

ISOFEEMALE LINES OF *TRICHOGRAMMA PRETIOSUM* RILEY

Eggs of the tobacco hornworm, *Manduca sexta* (L.) (Lepidoptera: Sphingidae), were collected from tomato plants at the University of California South Coast Field Station, Irvine, California, USA (33.6833333°N, 117.7166667°W). The local climate is Mediterranean (Köppen Csa) (Kottek et al. 2006). A single female of *T. pretiosum* collected from each host egg was mated with a male from the same egg and reared individually to start an isofemale line. The isofemale lines were kept under laboratory conditions, using eggs of the factitious host *Ephesia kuehniella* Zeller (Lepidoptera: Pyralidae), which were less than 24 h old and sterilized under UV light. In each subsequent generation, a single female was mated with a male from the same clutch of eggs and used to initiate the next generation. This inbreeding protocol was followed for 9 generations. According to Li (1955), after 9 generations the resulting isofemale lines should have an inbreeding coefficient of at least 86%. This inbreeding protocol resulted in elimination of most of the genetic variation present in the isofemale lines, leaving less than 14% of the initial heterozygosity.

In the *T. pretiosum* populations collected in the field, we found 3 different mitochondrial Cytochrome c oxidase COI haplotypes (Ma, Mb, and Mc), which differed in a few nucleotides from the sequence of the most common mitochondrial COI (Mcom). We used backcrossing protocols to create 3 populations of each isofemale line marked by nuclear DNA, and each population differed only in its mitochondrial marker. The rearing protocol for these populations followed the method described by Coelho Jr. et al. (2016), primarily always using 1 female offspring crossed with 1 male with known nuclear DNA.

The isofemale lines used in the flight tests were the same lines that were used in the field experiments by Coelho Jr. et al. (2016). These lines were classified into 3 categories: “best” isofemale lines with the highest fertility and sex ratio; “intermediate” isofemale lines with medium levels of fertility and sex ratio; and “worst” isofemale lines with the poorest reproductive capacity (fertility and sex ratio) (see Table 1). The USA isofemale lines were compared with a Brazilian isofemale line collected in a corn field in the municipality of Piracicaba, São Paulo State, Brazil (23.1666667°S, 48.0500000°W) (Table 1), with a humid

subtropical climate (Köppen Cwa). For the Brazilian isofemale line, the COI DNA was amplified by real-time polymerase chain reaction (PCR) to identify the mitochondrial type.

PROCEDURES FOR THE FLIGHT TEST

The flight test unit used was the Escola Superior de Agricultura “Luiz de Queiroz” (ESALQ) model proposed by Prezotti et al. (2002) based on Dutton and Bigler (1995). The unit consisted of a polyvinyl chloride (PVC) cylinder (10 × 18 cm, diam × ht) with the top covered with a Petri dish 15 cm in diam, covered with transparent entomological glue (Coly®, Mombuca, São Paulo State, Brazil) to capture flying adults of *T. pretiosum*. The inner wall of the cylinder was covered with a black sheet of paper making the top of flight test unit lighter than the bottom. On this sheet of black paper, a ring of glue 0.5 cm thick was applied 3.5 cm from the bottom of the tube, to form a barrier to capture insects that walked upward. A card containing approximately 100 parasitized eggs, from which wasps were about to emerge, was placed at the bottom of a glass vial (1.5 × 8.5 cm, diam × ht) in the center of the PVC cylinder (Fig. 1) (Prezotti et al. 2002). This vial contained a droplet of pure honey placed in the upper wall as food for the *T. pretiosum* adults.

The flight propensity of each *T. pretiosum* isofemale line was tested under 2 different RH conditions: 30 ± 10% (simulating summer humidity in Irvine, California, USA) and 80 ± 10% (simulating summer humidity

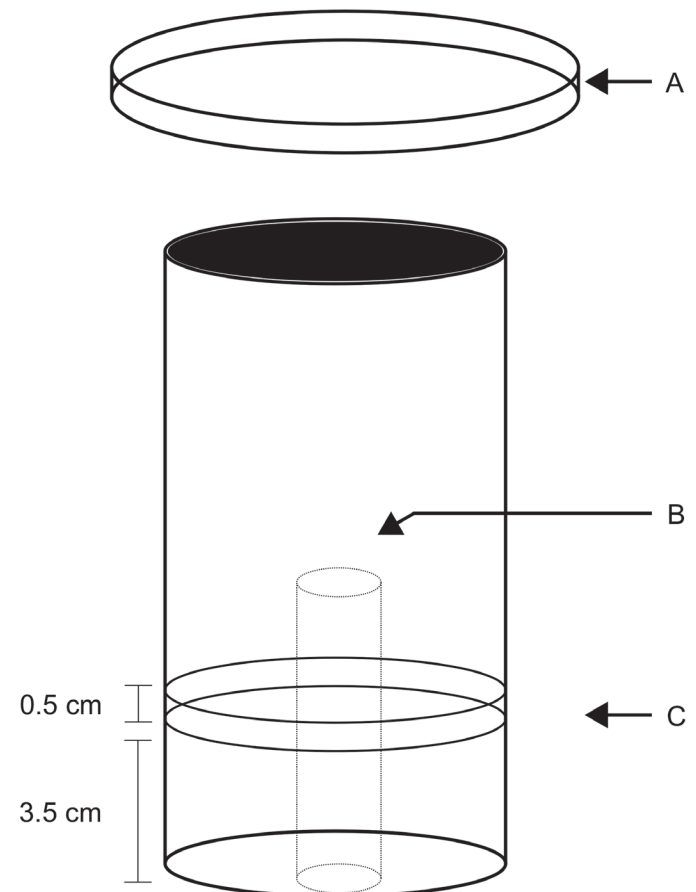

Fig. 1. Unit for flight test model ESALQ: (A) transparent Petri dish with glue to capture flying *Trichogramma pretiosum* wasps, (B) glass tube (10 × 18 cm, diam × ht) to allow expansion of wings containing a droplet of pure honey to feed adults, and (C) glue ring 3.5 cm from the tube bottom to capture walking insects (Prezotti et al. 2002).

Table 1. Classification based on fertility and sex ratio under laboratory conditions of 6 isofemale lines of *Trichogramma pretiosum* used in the experiment. Temperature: 25 ± 1 °C; relative humidity: 60 ± 10%; photoperiod 14:10 h (L:D).

Isofemale lines	Classification ¹
Irvine-47 A	Best
Irvine-47 B	Best
Irvine-43 A	Intermediate
Irvine-37 B	Intermediate
Irvine-51 C	Worst
Piracicaba	Not classified

¹Classification of isofemale lines by Coelho et al. (2016).

in Piracicaba, São Paulo State, Brazil) in a climate-controlled chamber at 25 ± 1 °C and a photoperiod of 14:10 h (L:D). The tests were repeated 5 times for each isofemale line and RH.

The insects were left in the flight-test units for 3 d, after which the test units were placed in a freezer (-20°C) in order to kill all the insects for counting. We evaluated the number of wasps that walked (caught in the lower glue band), flew (caught in the glue in the Petri dish), and non-flying (found below the lower glue band). The numbers in each location were expressed as the percentage of the total number of wasps.

STATISTICAL ANALYSIS

A multinomial model (nnet package) was fitted to the data for flying, walking, and non-flying individuals, including the effects of isofemale line and humidity in the linear predictor, as well as the interaction between these factors. The significance of effects was assessed through likelihood-ratio (LR) tests between the full model and reduced models. Differences between the proportions of flying, walking, and non-flying individuals from each isofemale line in the different humidity conditions were assessed based on confidence intervals for the model coefficients. Pearson's coefficient was used to analyze the correlation between the mean percentage of flying parasitoids in the laboratory. The mean used was calculated using the percentage of flying parasitoids per California isofemale line in both humidity conditions, and the number of egg cards parasitized by wasps from the same isofemale lines in the field experiment carried out by Coelho Jr. et al. (2016). The analyses were conducted using the statistical software R (R Development Core Team 2017).

Results

The multinomial model showed that there was a significant interaction between RH and isofemale lines ($LR = 73.14$; $df = 10$; $P < 0.001$, Table 2; see Supplemental information), and hence there are differences between the isofemale lines in the percentages of flying, walking, and non-flying wasps. The Brazilian isofemale line (Piracicaba) showed a lower percentage of flying individuals at 30% RH compared with 80% RH (Fig. 2). At 30% RH, simulating summer in a Mediterranean climate, the percentage of flying to non-flying wasps from the Piracicaba line was similar (Fig. 2). For the Piracicaba isofemale line at 30% RH, there were 27% fewer flying insects than at 80% RH (Fig. 2) with a variation of 49.5 and 76.7%, respectively. For the California isofemale lines (47A, 47B, 43A, 37B, and 51C) the percentage of individuals that flew was higher than the proportion that did not fly (Fig. 2). At higher RH, simulating summer humidity in a subtropical climate, all lines had a higher percentage of flying than non-flying and walking individuals, with more

than 64% flying (Fig. 2). The percentage of flying to walking individuals also was significantly higher at 30% RH compared with 80% RH.

The percentage of walking to non-flying individuals was highest for isofemale lines 47A and 47B at 80% RH (Fig. 2). At this RH, the Piracicaba isofemale line showed a higher percentage of non-flying than walking individuals. The isofemale line 37B, 43A, and 51C presented no significant differences between non-flying and walking individuals (Fig. 2). At 30% RH the lines 43A, 47A, 47B, and 51C have similar percentages of walking and non-flying individuals. The lines 37B and Piracicaba showed a higher percentage of non-flying individuals, compared with walking individuals (Fig. 2).

The Pearson's test showed very low, negative, and non-significant correlations between the mean number of flying individuals recorded in the laboratory for each line, this research, and the mean number of egg cards parasitized by each California isofemale lines in a cornfield in Brazil (data from Coelho Jr. et al. 2016; $\rho = -0.26$; $P = 0.66$).

Discussion

The isofemale lines of *T. pretiosum* vary in reproductive ranking (fertility and sex ratio) in the laboratory, which predicts the field performance (number of offspring produced in field conditions) (Coelho Jr. et al. 2016). Apparently, these differences in biological attributes did not affect the flight propensity of *T. pretiosum* lines, as insects from California, USA, showed similar flight propensity in both RH tested and between the isofemale lines. The percentage of flying versus non-flying *T. pretiosum* was similar in the Piracicaba isofemale line at low humidity, differing from the California isofemale lines and its own performance at 80% RH. Possibly, low RH hindered distention of the wings in the Piracicaba isofemale line, which did not occur with the California isofemale lines adapted to low RH.

Fournier and Boivin (2000) reported that *T. pretiosum* from Canada displayed a better flight activity compared with *Trichogramma evanescens* Westwood introduced from Egypt, possibly because it was adapted to the climate in Canada due to evolutionary pressures. It is known that climatic factors affect locomotion, dispersion, and flight of *Trichogramma* (Forsse et al. 1992; Bouchier & Smith 1996; Dutton et al. 1996; Fournier & Boivin 2000). Even sudden changes in atmospheric pressure, either increasing or decreasing, also affect the flight of *Trichogramma* (Fournier et al. 2005). Bouchier and Smith (1996) reported that there is an inverse correlation between RH and the likelihood of parasitism by *Trichogramma minutum* Riley. For isofemale lines of *T. pretiosum* used in the present study, this correlation was not observed under field conditions (Coelho Jr. et al. 2016); however, under laboratory conditions, using flight test units, *T. pretiosum* isofemale lines from the dry climate (California) flew similarly at high and low RH.

The percentage of walking *T. pretiosum* was different for some isofemale lines. Isofemale line 43A, classified as "intermediate" in relation to its reproductive attributes, walked less at 80% RH than isofemale line 47B, which was classified as "best," classifications were according to Coelho Jr. et al. (2016). Isofemale lines 47B and 37B walked less at lower RH (30%). It is important to note that insects from lines that walked at low RH flew under high humidity conditions. Dutton and Bigler (1995) consider walking the most important locomotion activity of *Trichogramma* in search of eggs after it reaches the target plant by flying. The lowest percentage of walking was observed in isofemale line 43A at high RH; this may indicate that the field results obtained by Coelho Jr. et al. (2016) are related to a low propensity to search for eggs under field conditions.

Quality control of egg parasitoids is a key factor for the success of biological control programs (van Lenteren 2003). The results of this

Table 2. Significance of relative humidity (RH) levels within each *Trichogramma pretiosum* isofemale line level and isofemale line levels within each relative humidity level. LR = likelihood-ratio test statistic, df = degrees of freedom, and P-value.

Source of variation	LR	df	P value
Isofemale within RH 30%	82.54	10	< 0.0001
Isofemale within RH 80%	87.84	10	< 0.0001
RH within isofemale 47 A	6.16	2	0.0459
RH within isofemale 47 B	8.84	2	0.0120
RH within isofemale 37 B	25.11	2	< 0.0001
RH within isofemale 43 A	4.65	2	0.0977
RH within isofemale 51 C	2.51	2	0.2857
RH within isofemale Piracicaba	49.00	2	< 0.0001

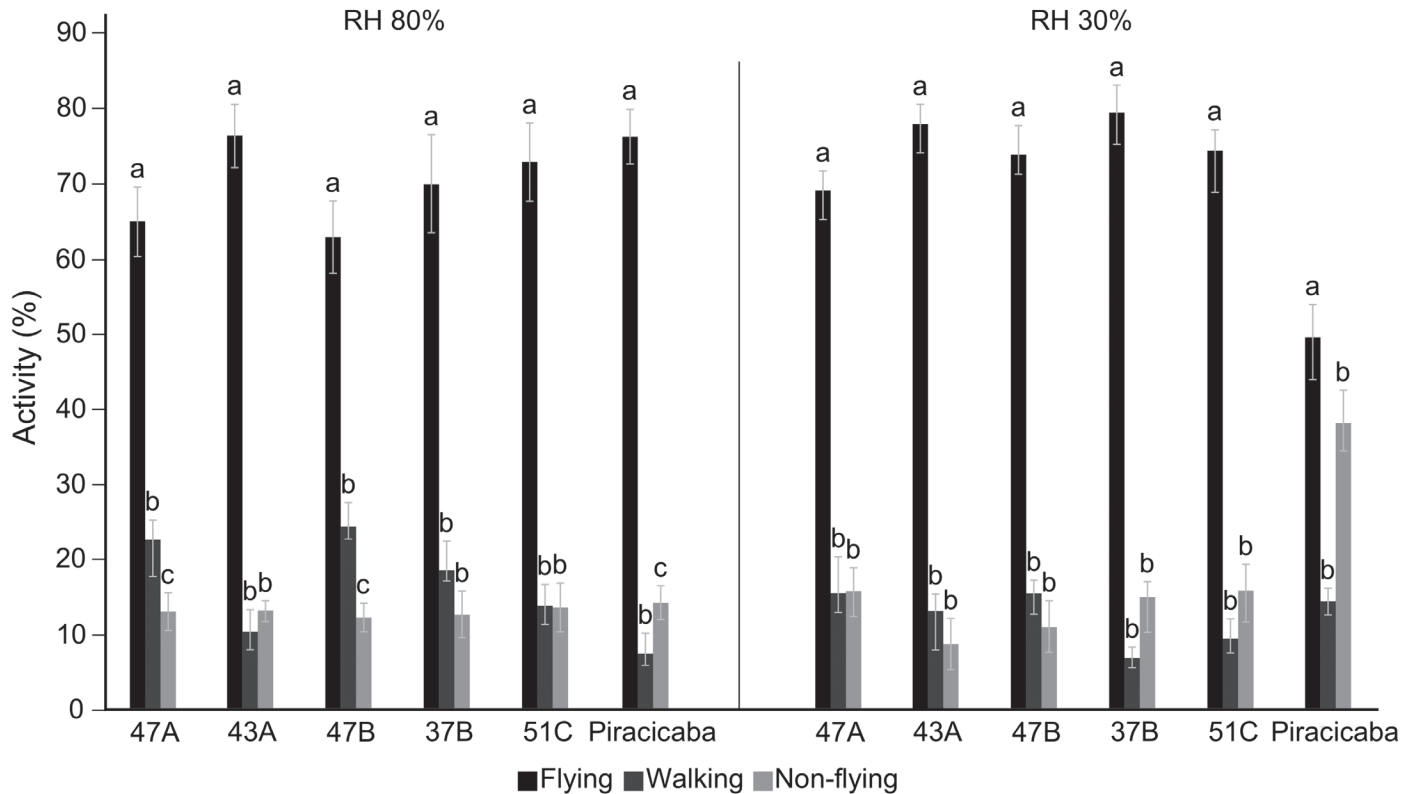

Fig. 2. Movement bias (flying, walking, and non-flying) of *Trichogramma pretiosum* individuals at 2 relative humidity (RH) conditions, RH 30 ± 10% and 80 ± 10%. Temperature: 25 ± 1 °C, photoperiod 14:10 h (L:D). Error bars indicate means ± standard errors. Within a type of movement and RH, bars topped by the same letter are not significantly different ($P > 0.05$).

study showed differences in flight propensity between the different isofemale lines. Insects collected at the same site in the USA and with different laboratory (fertility and sex ratio) and field performances (proportions of offspring) showed similar flight propensity; however, the Brazilian isofemale line flew less at 30% RH. Thus, although the flight test is an important component to monitor quality of *Trichogramma*, it is crucial to conduct such tests comparatively, taking into account the place of origin of the insect.

The efficiency of *Trichogramma* spp. depends on environmental conditions where the parasitoids will be released. Unmatched conditions of release sites may lead to poor results in pest control. Parra et al. (2015) reported that some biological control programs were not successful because they did not take into consideration the microclimatic requirements of lines. On the other hand, the field parasitism capacity of the California isofemale lines (Coelho Jr. et al. 2016) showed little correlation to their laboratory flight propensity. The genetically different California isofemale lines varied widely in their parasitism rates in the field, and these field performances correlated well with their laboratory performances, assessed by fertility and offspring sex ratio (Coelho Jr. et al. 2016). However, the laboratory flight test used here proved to be insufficiently sensitive to discriminate *T. pretiosum* isofemale lines that perform differently in the field, indicating that in our case this test cannot identify the best line for field release. Moreover, the California isofemale lines were not affected at 80% RH, a highly different condition from their natural habitat in Irvine, California, which is naturally dry with sparse rainfall and low RH.

The flight propensity of 1 *T. pretiosum* isofemale line collected in Piracicaba, São Paulo State, Brazil, with subtropical climate was adversely affected by low humidity conditions. However, the flight test proved to be insufficiently sensitive to predict field performance, and was unable

to discriminate *T. pretiosum* isolines from Irvine, California, USA, from a site with Mediterranean climate. The California isolines flew equally in the laboratory flight test, despite different biological traits in field (parasitism performance) and laboratory (fertility and sex ratio).

Acknowledgments

We thank the São Paulo Research Foundation (FAPESP) for financial support (process no 2011/17397-5). We also thank Rafael de Andrade Moral for his support in the statistical analyses.

References Cited

- Bourchier RSL, Smith SM. 1996. Influence of environmental conditions and parasitoid quality on field performance of *Trichogramma minutum*. *Entomologia Experimentalis et Applicata* 80: 461–468.
- Cerutti F, Bigler F. 1995. Quality assessment of *Trichogramma brassicae* in the laboratory. *Entomologia Experimentalis et Applicata* 75: 19–26.
- Coelho Jr A, Rugman-Jones PF, Reigada C, Stouthamer R, Parra JRP. 2016. Laboratory performance predicts the success of field releases in inbred lines of the egg parasitoid *Trichogramma pretiosum* (Hymenoptera: Trichogrammatidae). *Plos One* 11: e0146153.
- Cônsoli FL, Parra JRP, Zucchi RA [eds.]. 2010. *Egg Parasitoids in Agroecosystems with Emphasis on Trichogramma*. Springer, Dordrecht, The Netherlands.
- Dutton A, Bigler F. 1995. Flight activity assessment of the egg parasitoid *Trichogramma brassicae* (Hym.: Trichogrammatidae) in laboratory and field conditions. *Entomophaga* 40: 223–233.
- Dutton A, Cerutti F, Bigler F. 1996. Quality and environmental factors affecting *Trichogramma brassicae* efficiency under field conditions. *Entomologia Experimentalis et Applicata* 81: 71–79.
- Filippov NA. 1992. Place of biocontrol in integrated pest management in the former USSR, pp. 1–16. In Soper RS, Filipov NA, Alimukhamedov SN [eds.], *Cotton – integrated pest management*. USDA, Beltsville, Maryland, USA.

- Flanders SE. 1927. Biological control of the codling moth. *Journal of Economic Entomology* 20: 644.
- Forsse E, Smith SM, Bouchier S. 1992. Flight initiation in the egg parasitoid *Trichogramma minutum*: effects of ambient temperature, mates, food, and host eggs. *Entomologia Experimentalis et Applicata* 62: 147–154.
- Fournier F, Pelletier D, Vigneault C, Goyette B, Boivin G. 2005. Effect of barometric pressure on flight initiation by *Trichogramma pretiosum* and *Trichogramma evanescens* (Hymenoptera: Trichogrammatidae). *Environmental Entomology* 34: 1534–1540.
- Fournier F, Boivin G. 2000. Comparative dispersal of *Trichogramma evanescens* and *Trichogramma pretiosum* (Hymenoptera: Trichogrammatidae) in relation to environmental conditions. *Environmental Entomology* 29: 55–63.
- Guzmán-Larralde A, Cerna-Chávez E, Rodríguez-Campos E, Loyola-Licea JC, Stouthamer R. 2014. Genetic variation and the performance of a mass-reared parasitoid, *Trichogramma pretiosum* (Hymenoptera: Trichogrammatidae), in laboratory trials. *Journal of Applied Entomology* 138: 315–391.
- Kottek M, Grieser J, Beck C, Rudolf B, Rubel F. 2006. World map of the Köppen-Geiger climate classification updated. *Meteorologische Zeitschrift* 15: 259–263.
- Li CC [ed.]. 1955. *Population Genetics*. University of Chicago Press, Chicago, Illinois, USA.
- Parra JRP. 2010. Mass rearing of egg parasitoids for biological control programs, pp. 267–292 *In* Cõnsoli FL, Parra JRP, Zucchi RA [eds.], *Egg Parasitoids in Agroecosystems with Emphasis on Trichogramma*. Springer, New York, USA.
- Parra JRP, Zucchi RA [ed.]. 1997. *Trichogramma e o controle biológico aplicado*. FEALQ, Piracicaba, Brazil.
- Parra JRP, Zucchi RA, Coelho Jr A, Geremias LD, Cõnsoli FL. 2015. *Trichogramma* as a tool for IPM in Brazil, pp. 472–496 *In* Vinson B, Greenberg SM, Liu T, Rao A, Volosciuk LF [eds.], *Augmentative Biological Control Using Trichogramma spp.: Current Status and Perspectives*. Northwest A&F University Press, Shaanxi, China.
- Prezotti L, Parra JRP, Vencovsky R, Dias CT dos S, Cruz I, Chagas MCM. 2002. Teste de vôo como critério de avaliação da qualidade de *Trichogramma pretiosum* Riley (Hymenoptera: Trichogrammatidae): adaptação de metodologia. *Neotropical Entomology* 31: 411–417.
- R Development Core Team. 2012. R version 2.15.1. www.R-project.org (last accessed 17 May 2018).
- Sorati M, Newman M, Hoffmann AA. 1996. Inbreeding and incompatibility in *Trichogramma nr. brassicae*: evidence and implications for quality control. *Entomologia Experimentalis et Applicata* 78: 283–290.
- Thomson L, Hoffmann A. 2002. Laboratory fecundity as predictor of field success in *Trichogramma carverae* (Hymenoptera: Trichogrammatidae). *Journal of Economic Entomology* 95: 912–917.
- van Lenteren JC. 2003. Need for quality control of mass produced biological control agents, pp. 1–18 *In* Lenteren JC van [ed.], *Quality Control and Production of Biological Control Agents: Theory and Testing Procedures*. CABI, Wallingford, United Kingdom.
- Wajnberg E, Hassan SA [eds.]. 1994. *Biological Control with Egg Parasitoids*. CABI, Wallingford, United Kingdom.