



Cooperative Extension Service  
Institute of Food and Agricultural Sciences

## Turf Irrigation for the Home<sup>1</sup>

F.S. Zazueta, A. Brockway, L. Landrum and B. McCarty<sup>2</sup>

### TURF AND WATER

Water is essential for turf growth. It is required for germination, photosynthesis and as a part of the turf. Most of the water absorbed by turf is transpired through the leaves into the atmosphere. This water moves nutrients from the soil into the plant, but equally important, it eliminates heat buildup from solar radiation.

The water applied by an irrigation system will evaporate from the soil and be transpired from plant surfaces. Evaporation and transpiration (evapotranspiration) depend mostly on the climate around the plant, thus, the amount of water used by turf changes with the seasons (see Figure 1). Because of this, for a well-managed turf, irrigation frequency should change with the time of year.

### THE SOIL RESERVOIR

Only water that is in contact with the roots can be absorbed by the plant. The volume of soil where water can be stored is as deep as the roots are. Root depth is affected by mowing, fertilizing and irrigation practices (see Figure 2 and references 1 and 2). A well-managed turf system will develop most of its roots in the first 12 inches of the soil. Another important property of the soil reservoir is that soils have a limited ability to store water. The larger the pores in the soil the less water the soil will hold. Table 1 shows the soil-water holding capacity (SWHC) for different types of soils.

### THE IRRIGATION SYSTEM

An irrigation system is a collection of hydraulic devices that deliver water to the turf. An irrigation system may consist of a single sprinkler with a hose that is moved from location to location. Or it may consist of an elaborate pipe network with pop-up sprinklers that irrigate based on soil moisture sensor readings. Both of these systems can be equally efficient if used properly. To use an irrigation system properly it is necessary to understand how sprinklers operate and where they should be placed.

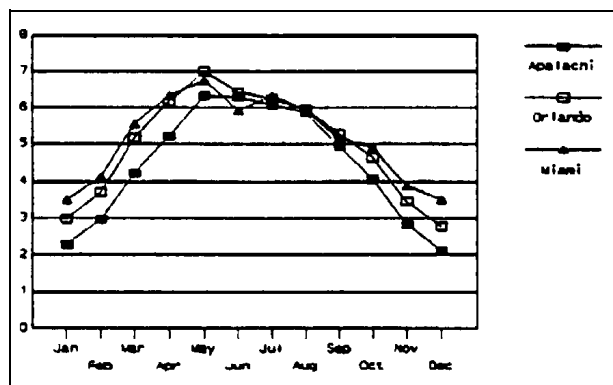

Figure 1. Inches of monthly evapotranspiration at different locations in Florida.

1. This document is Circular 829, one of a series of the Agricultural and Biological Engineering Department, Florida Cooperative Extension Service, Institute of Food and Agricultural Sciences, University of Florida. Date first printed, April 1995; reviewed May 1999. Please visit the EDIS Web site at <http://edis.ifas.ufl.edu>.
2. F.S. Zazueta, Associate Professor, Department of Agricultural and Biological Engineering; A. Brockway, Extension Agent I in Urban Horticulture, District III, Volusia County, Deland; L. Landrum, Extension Agent II in Ornamental Horticulture, District III, Volusia County; and B. McCarty, Assistant Professor Department of Environmental Horticulture, Cooperative Extension Service, Institute of Food and Agricultural Sciences, University of Florida, Gainesville, 32611.

The Institute of Food and Agricultural Sciences is an equal opportunity/affirmative action employer authorized to provide research, educational information and other services only to individuals and institutions that function without regard to race, color, sex, age, handicap, or national origin. For information on obtaining other extension publications, contact your county Cooperative Extension Service office.  
Florida Cooperative Extension Service / Institute of Food and Agricultural Sciences / University of Florida / Christine Taylor Waddill, Dean

## How sprinklers work

A sprinkler is a device used to produce artificial rainfall (sprinkler precipitation). Its purpose is to apply water as uniformly as possible over a given area. Most sprinklers are of the impact, gear-driven, or stationary spray nozzle types. Impact and gear-driven nozzles produce a stream of water that is broken up by the impact arm or a pin that protrudes into the flow stream. As the sprinkler rotates it covers a circular area producing a conical water distribution pattern (see Figure 3 top). Since the water applied to the surface of the turf is nearly cone-shaped, sprinklers must be spaced so that the areas covered by the sprinklers overlap each other. Sprinklers that are spaced too far apart result in a watering pattern that is not uniform. Properly spaced sprinklers result in a uniform watering pattern (see Figure 3 bottom).

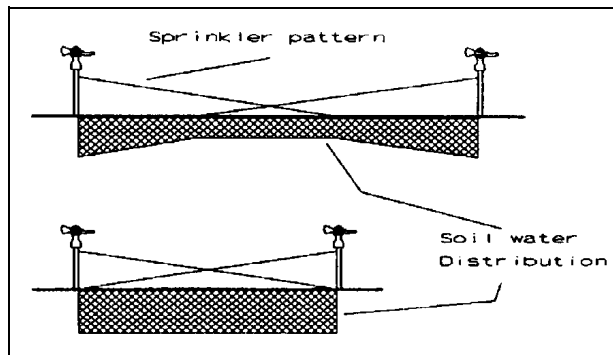

**Figure 3.** Water application distributions resulting from sprinkler irrigation. Excessive spacing results in a "dry" spot between sprinklers.

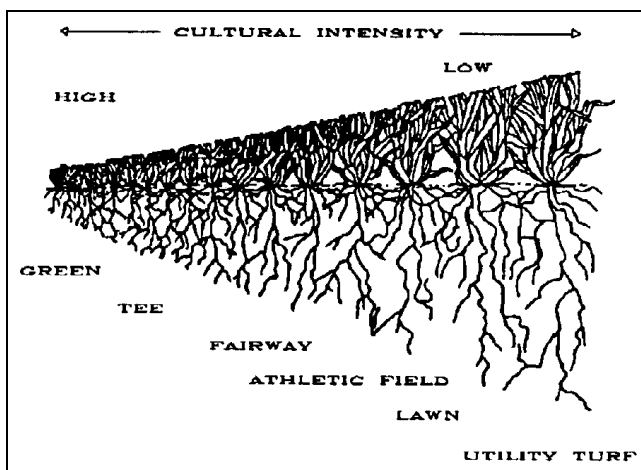

**Figure 2.** Relative size of turf resulting from different cultural intensity.

In general, sprinkler overlap should be such that water from a sprinkler should nearly reach the neighboring sprinklers. When the spacing of sprinklers is more than 60 percent of the diameter of throw of the sprinklers, it's very likely that the system will not perform well. An exception to this is the stationary spray nozzle sprinkler that is designed to put out uniform precipitation patterns with little or no overlap. It is important that sprinklers are operated at the pressure recommended by the manufacturer. Sprinklers working at low pressure will produce a doughnut pattern around the sprinkler. Sprinklers operating at high pressure will break up the stream, producing excessive small droplets that will cause most of the water to be deposited close to the sprinkler or lost to evaporation and wind drift.

## Placing sprinklers in a yard

Impact or gear-driven sprinklers should be used in large areas. Stationary spray nozzles should be used for small areas or strips. Most impact sprinklers used for small turf areas will work well at spacings between 35 and 45 feet. Gear-driven sprinklers will work well at spacings between 25 and 35 feet. Stationary spray nozzle sprinklers will work well in spacings of 8 to 15 feet. Once a sprinkler is selected, the recommended spacing and pressure can be obtained from the manufacturer. If these are not available, operate at a 25 psi to 30 psi pressure and measure the diameter. Regardless of whether you irrigate using hose and sprinkler, or a solid set system, the placement of the sprinklers will be the same. A solid set system will use polyethylene or PVC pipe to deliver water to the sprinklers. A hose- and-sprinkler system will require that the sprinkler be moved from location to location to apply water. Do not mix different types of sprinklers (impact, gear-driven or spray) to irrigate a zone.

## IRRIGATION SCHEDULING

Two questions must be answered when scheduling irrigation:

**WHEN DO I IRRIGATE?** Water should be applied to turf only when soil-water in the root system has been depleted to an unacceptable level, usually by 1/2 to 2/3 of the stored soil-water. There are several ways to determine when the soil-water reservoir has been depleted beyond an acceptable level. These are:

- *Visual inspection of the turf.* Becoming familiar with the way that turf reacts when water is becoming scarce

in the soil is a common method of deciding when to apply irrigation. Common symptoms of water stress include leaf color changes to a bluish-gray tint, footprints that linger long after being made, and curled or folded leaf blades.

- *Estimations based on climatic records.* Past history of climate can be used to estimate how often irrigation should be applied to turf. Figure 4 shows the expected number of days that soil-water will last for a typical Florida sandy soil that can hold 1 inch of water per foot of soil and is irrigated to a depth of one foot. If your root depth and soil-water holding capacity are different, multiply the number of days in Figure 4 by the value of your root depth and then by the value of your soil-water holding capacity.
- *Direct measurement of soil moisture.* Using sensors for measuring the amount of available water in the soil is another way to determine when to irrigate. One such sensor is the tensiometer (see Figure 5). As the soil dries, water moves out of the tensiometer through the ceramic, causing a suction that is measured by the vacuum guage. Tensiometers can be used to automatically schedule irrigation. (See reference 3 for a discussion on the use of tensiometers and installation instructions.)

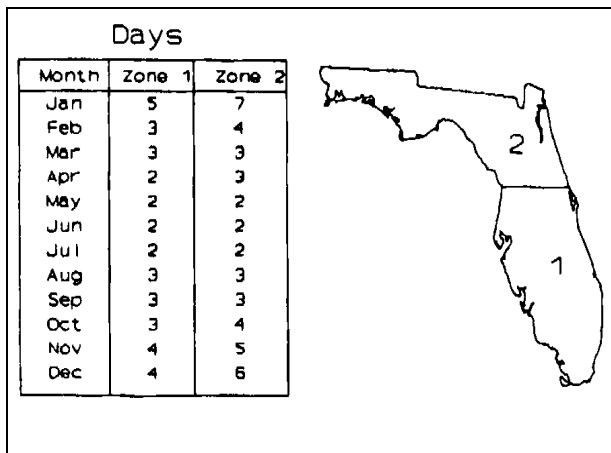

**Figure 4.** Number of days soil water stored in the root system will last before irrigation or rain is required.

**HOW MUCH WATER SHOULD I APPLY?** The quantity of water applied to turf should not exceed the amount required to refill the soil occupied by the root system (poor quality water may require higher volumes for leaching). Regardless of the time of year, for an established turf the quantity of water applied at each

irrigation should always be the same. Irrigation will not be required as often during low demand periods. Typical Florida soils will be able to hold at least 1 inch of water per foot of soil. The amount of water to apply to a one-foot-deep soil water reservoir, which has been depleted to 50 percent and has a water holding capacity of one inch per foot (1"/ft), is 2/3 of an inch of water. This assumes an irrigation efficiency of 75 percent. The total volume required will depend on the size of the area being irrigated and the soil-water holding capacity. Figure 6 shows the volumes of water required for different size areas of a soil that holds one inch of water per foot.

## APPLYING IRRIGATION

In order for irrigation to be successful and efficient, the volume of water applied must be measured. There are several ways to measure irrigation volumes of water.

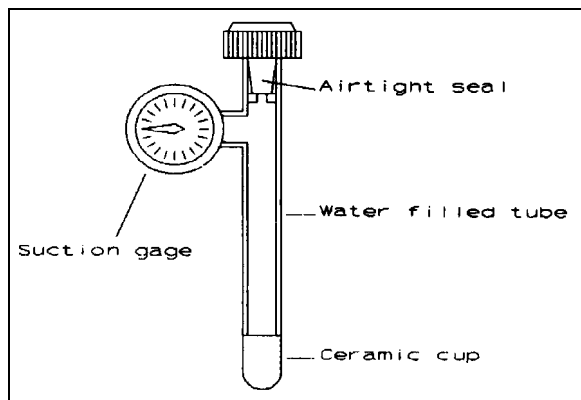

**Figure 5.** Tensiometer.

- *Using a water meter.* In a permanently installed system a water meter should be included as part of the irrigation system. In systems that are connected to an urban water supply, the meter installed by the service company can be used. The time required to apply the necessary water can be easily determined by observing the water meter to measure how much water is applied by the irrigation system in a minute. For example, a system that requires 1200 gallons is turned on, and from the meter it is observed that 12 gallons per minute are being used. Thus, the time that the irrigation system should be turned on is 100 minutes (1200 gallons divided by 12 gallons per minute).

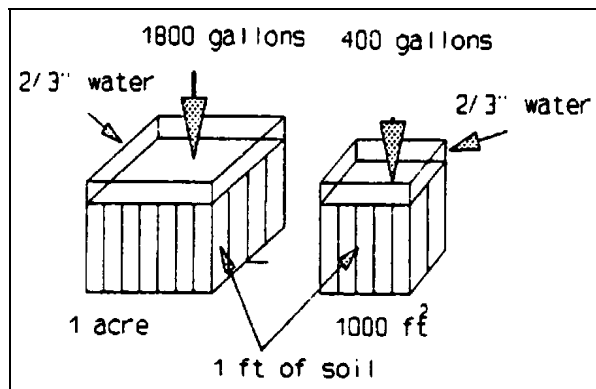

**Figure 6.** Irrigation volumes required for different size areas to replenish a soil (1"/ft SWHC) depleted to 50% using an impact sprinkler.

- Measuring the depth of water applied.* When a water meter is not available place five wide-mouth, flat-bottom cans spaced equally along the diagonal of four sprinklers (see Figure 7). After 20 minutes of irrigation, turn the system off and use a ruler to measure how deep the water is in each can. Average the five measurements and use the average to determine the time required to apply 2/3 of an inch of water (from Figure 8). For example, if a 20-minute can test resulted in an average water depth of 1/2 of an inch, the time that irrigation system should be turned on in order to apply 2/3 of an inch of water is obtained from Figure 8 as 27 minutes. Any water applied after 27 minutes will be wasted as deep percolation.
- If a hose and sprinkler is used with this method, set the sprinkler pattern to 1/4 of a circle before carrying out the test. Move the sprinkler to each corner of the irrigated area and irrigate for five minutes from each corner for a total of 20 minutes. Obtain the irrigation duration from Figure 8 using the average depth in the cans as previously explained. When irrigating the turf, apply water for the irrigation duration when the hose-and-sprinkler is used in full circle; for 1/2 the irrigation duration when the hose-and-sprinkler is used in half circle; and for 1/4 the irrigation duration when the hose- and-sprinkler is used in quarter circle. Also, if possible, carry out the test in the early morning hours and under no-wind conditions.
- Using automatic shut-off valves.* A variety of automatic shut-off valves are available that are especially suited for irrigating with a hose and sprinkler. These allow the user to set a time period or

volume to apply. These are inexpensive and convenient and reduce water waste due to lack of attention to hose-and-sprinkler systems.

- Using soil-moisture sensors.* When permanently installed irrigation systems are run using timers, sensors can be used to control these systems. Reference 3 discusses how to wire a tensiometer with a timer to use this method. The timer should be set to irrigate every day to apply about 1/3-1/2 of an inch of water during early morning hours for best efficiency. The tensiometer will allow irrigation only if water is required.

## FINE-TUNING THE SCHEDULE

Up to this point the irrigation volume to apply has been given for a root depth of one foot in a soil that holds one inch of water per foot, as 1800 gal/acre or 2/3 of an inch of water. What happens if the soil holds more or less than one inch of water per foot, or the root depth is different from one foot? Moreover, what happens to the number of days that water stored in the soil will last? To correct for these differences multiply the soil-water holding capacity and the root depth in feet by the values recommended previously. For example, assume that turf for the month of May is to be irrigated in region 2. The soil is a silty clay loam with a SWHC of 1.5" of water per foot, and the root depth is 1.25 ft (15 inches).

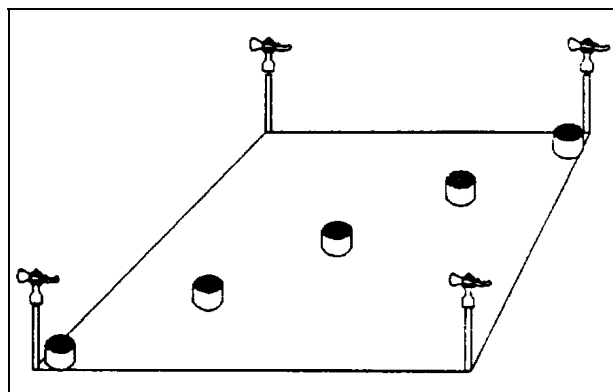

**Figure 7.** Test can distribution to measure application rate and uniformity.

The volume of water application is:

$$1800 \text{ gal/acre} \times 1.5 \times 1.25 = 3375 \text{ gal./acre}$$

or

$$400 \text{ gal}/1000 \text{ ft}^2 \times 1.5 \times 1.25 = 750 \text{ gal}/1000 \text{ ft}^2$$

The expected number of days in which irrigation or rainfall would be needed is:

$$2 \text{ days} \times 1.5 \times 1.25 = 3.75 \text{ days}$$

The same multiplications can be carried out for the irrigation duration obtained from the 20 minute can test to obtain the corrected irrigation duration.

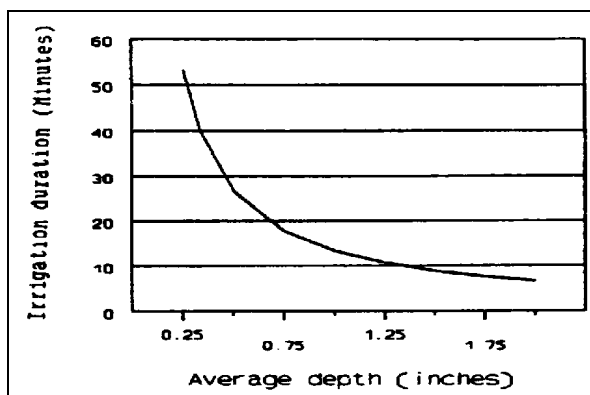

**Figure 8.** Time that an irrigation system should be on to apply 2/3 of an inch of water to a soil that has been depleted 50%.

## TESTING THE IRRIGATION SYSTEM

The performance of an irrigation system depends strongly on how well the system is designed. First, check the manufacturer's specifications. The irrigation system will not work well if sprinklers are spaced too far apart or operated outside the recommended pressure. This is true of hose-and-sprinkler systems through sensor-controlled systems. A simple test to evaluate the performance of the system is to measure the uniformity of application. This is done by using cans to measure depth of application as previously described. To obtain an idea of the distribution pattern use at least five cans along the diagonals of the sets of four sprinklers as shown in Figure 7. If possible, run the test under no-wind conditions. The variation of depth between the cans should be small ( $\pm 10\%$  of the average). If the applied depth is not fairly uniform it is indicative of design problems, such as improper spacing or operating pressure.

## CLOSING REMARKS

Turf requires water to maintain a healthy and uniform appearance. To reduce watering, use turf areas only where required in the landscape. Make use of mulched areas, especially in hard-to-reach places. Consider using drought-tolerant plants.

Irrigate by demand. Apply water only when the soil has been depleted. Always apply only the amount of water that is required to refill the soil. Change the frequency with which you irrigate and not the amount of water applied. As a guideline use the irrigation intervals in Figure 4. Keep track of the time since the last rain or irrigation, to determine when the next irrigation is due. (If it is a light rain, you will have to compensate.) Do not apply daily light irrigations (less than 1/4" depth of water). It has been shown that deep irrigations (more than 2/3" depth of water) applied less frequently provide better turf quality.

If possible, apply water during the early hours of the morning. The most efficient time to irrigate is from about 4:00 a.m. to 6:00 a.m. Also, avoid peak water use hours to insure that sufficient pressure is available to operate the system.

Detailed information and recommendations for turf management in Florida are available from your county Extension office.

## REFERENCES

- 1) Augustine, B.J. and C.H. Peacock. Mowing Your Florida Lawn. Fact sheet OH-10. IFAS, University of Florida. 1984.
- 2) Smith, G.S. Fertilizing Your Florida Lawn. Fact Sheet OH-20. IFAS, University of Florida. 1985.
- 3) Smajstrla, A.G., D.S. Harrison, and F.X. Duran. Tensiometers for Soil Moisture Measurement and Irrigation Scheduling. Circular 487. IFAS, University of Florida. 1984.

## GLOSSARY

**Cultural intensity:** The frequency of actions required to maintain a turf of certain quality for a given purpose. For example, a utility turf may require little or no attention. A

green will require nearly continuous attention to maintain its appearance and quality.

**Evapotranspiration:** The combined amount of water that leaves the soil by evaporation from the soil surface and transpiration from plant leaves.

**Germination:** The process by which plants emerge from seeds when environmental conditions are appropriate.

**Hydraulic:** Related to water and its movement through pipes, valves, etc.

**Irrigation frequency:** The number of times that irrigation is required over a time period. Irrigation frequency is generally larger during the summer months.

**Polyethylene:** A plastic material used in the manufacture of irrigation components.

**psi:** Pounds per square inch. A unit of measurement of pressure.

**PVC:** A plastic material used in the manufacture of irrigation components.

**Photosynthesis:** A process carried out by plants to convert solar energy and certain gases in the atmosphere into sugars.

**Transpiration:** The amount of water that is absorbed by the plant and evaporates into the air from the plant's leaves.

**Water quality:** The chemical, biological or physical properties of water that may affect turf. For example, salts and dissolved toxic substances.

**Table 1.** Soil-water holding capacities for different Florida soils (inches per foot).

SOIL TYPE	RANGE	AVERAGE
Sands and fine sands	0.20-1.00	0.75
Moderately coarse textured sandy loams to silty clay loams	1.00-1.50	1.25
Medium texture very fine sandy loams to silty clay loams	1.25-1.75	1.50
Fine and very fine texture silty clay to clay peats and mucks	2.00-3.00	2.50