



WORKBOOK

Florida 4-H Clothing and Textiles Program



Clothing Capers

Clothing is fun and an important part of your daily life. Think about how many places sell clothes. Think of all the different clothes that tell things about you. T-shirts tell which sports team is your favorite. Dresses and ties say that you have somewhere important to go. Warm clothes tell you that the weather is cool.

There are many ways that you can improve your wardrobe through your own skills and creativity. Through these activities, you will learn ways to care for your clothing to keep it looking its best, about fibers and fabrics, skills in being a good consumer, and even how to sew your own garments!

There are eight different action “scenes” in which you can learn new information and skills for all your future Clothing Capers! Explore the activities in each for a well balanced knowledge of clothing and textiles. There is more to learn than you ever imagined!



CREATIVITY

- Scene 1: Creative Construction...Setting The Stage
- Scene 2: Pattern Directing...Reading The Script
- Scene 3: How Good A Director Are You?...Act 1: Sew Some Jams



COMMUNICATION OF SELF

- Scene 1: The Spotlight's On You...Acting The Part
- Scene 2: Portraits Of Myself...Clean and Neat..Head To Feet!



CUTTING EDGE

- Scene 1: Of Fibers and Fabrics...What's Its Name?
Scene 2: The "In's and Out's" Of Fabrics...Fabric Fun Experiments



CHOICES

- Scene 1: Be Yourself...Choices Collage
Scene 2: Fashion Fun Count...Color Plays A Leading Role!
Scene 3: Wardrobe Planning



CONSUMERISM

- Scene 1: Be A Super Shopper...Label Ratings
Scene 2: How Good A Critic Are You?...Shopping Etiquette



CARE

- Scene 1: It's Important...Laundry Game
Scene 2: Going, Going, Gone...Which One Is Best?



CULTURE

- Scene 1: Zoom In On Culture...Tie-Dying Fun!



CAREERS

- Scene 1: Focus On Careers...Career Explorations
Scene 2: Career Capers...A Personal Portfolio



Creative Construction

Act 1

C
R
E
A
T
I
V
I
T
Y

What do movie making and sewing have in common? Creativity and FUN! Creative sewing can be fun. There are many important things to consider before you sew. It is important to know the proper tools to use, how to follow instructions, and recognize pattern symbols and markings.

Making a garment allows you to creatively design your outfit to be unique. You can also creatively change or repair garments with patches or make accessories to match your outfits.

Practice makes perfect, so spend time on your project. Each time you sew, it will be easier and easier!



Quick Tips



Set aside one place for your equipment. Storing everything in one place will keep you more organized.



Have a separate pair of scissors for your clothing and textile projects. Do not use these scissors to cut paper or other objects.



Develop a plan for making each project. Determine how long you think the project will take and what items you will need for each step. Finish each project before beginning another one.



...Setting the STAGE

Just as every movie requires a very skilled cameraman, you must become a very skilled machine operator. Demonstrate your knowledge at threading a sewing machine. Starting at the spool of thread, draw the path that the thread takes to the needle.

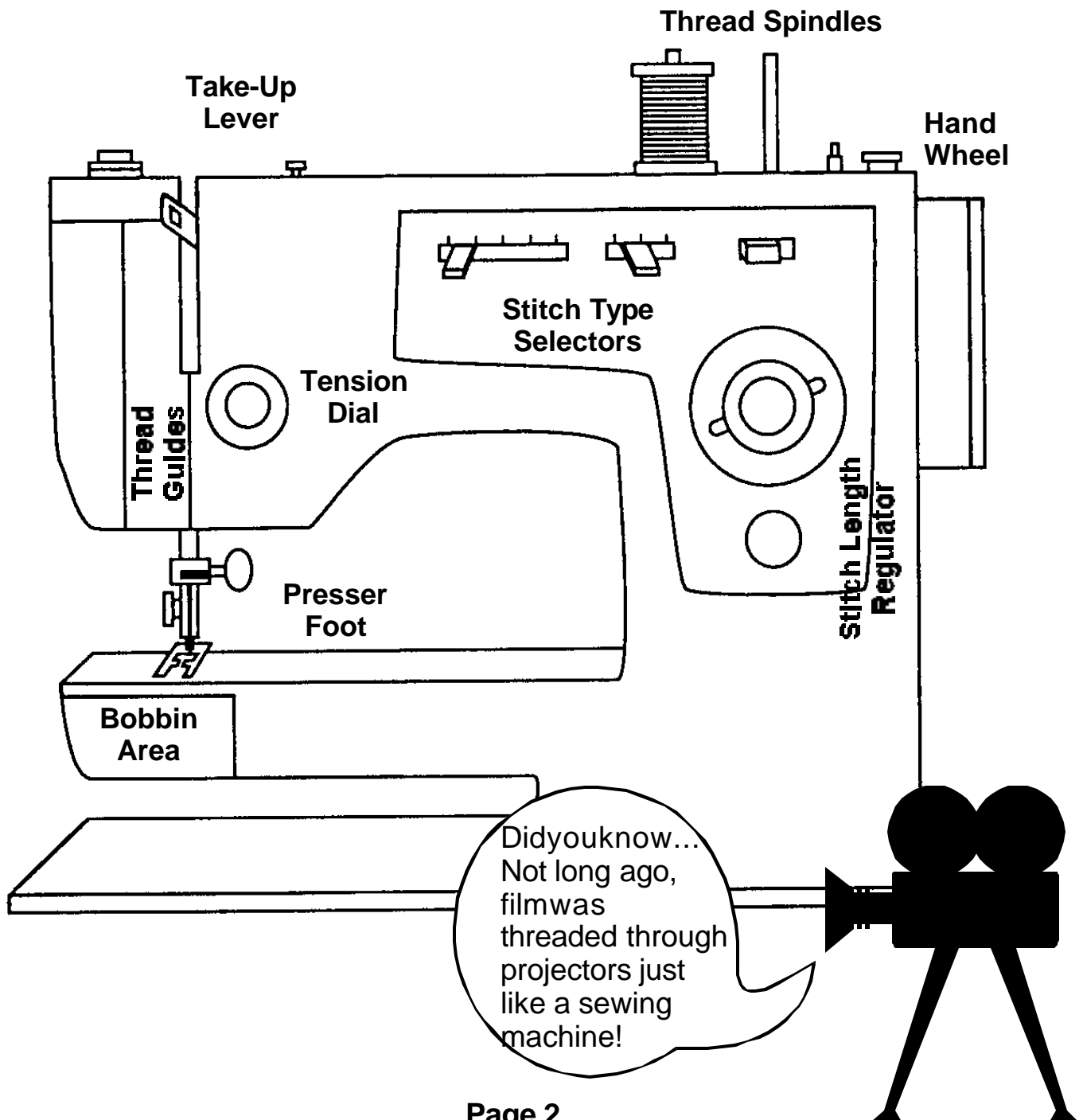

Pattern Directing...

A successful movie begins with a script of all the action scenes. The same is true for creative construction projects or making a garment. They both require some important information. As the director of your own project, you will need to learn to read and follow pattern directions and instructions.

What You Will Need:

- ✓ A pattern envelope

What You Do:

Using a pattern envelope, answer these questions:

Determine your size and figure type according to the measurements on the envelope. What is your size?

Select a view you would like to sew.

What's the fabric amount required for your view and size?

Find two suggested fabrics.

What are the required notions?

Briefly summarize the pattern description.

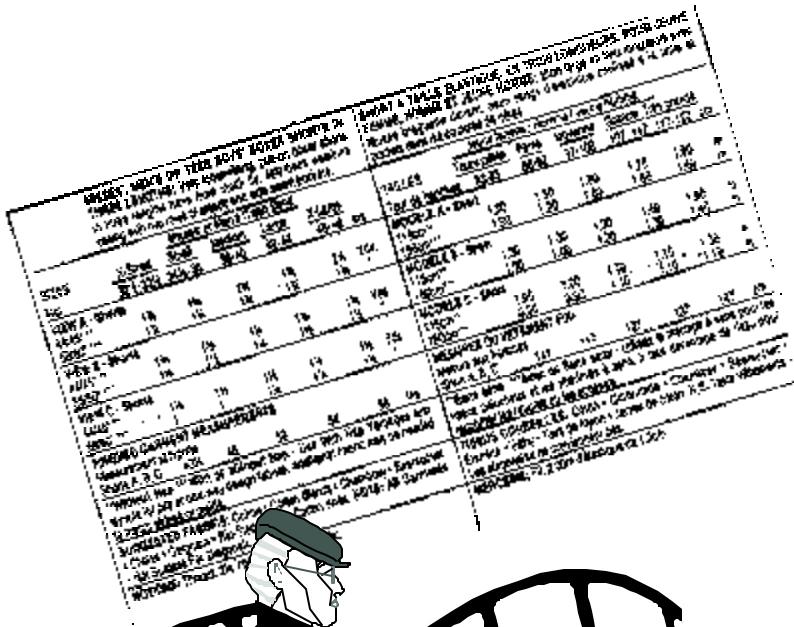

...Reading the Script

One of the jobs of the director is to make sure the script is followed. Understanding all the symbols and markings is part of the script for successful sewing projects. Patterns provide you with meaningful symbols and signs to keep you going in the right direction!

Do you know your pattern symbols? Beside each number below, write the name or purpose of the symbol.

1. _____
2. _____
3. _____
4. _____
5. _____
6. _____
7. _____
8. _____
9. _____
10. _____

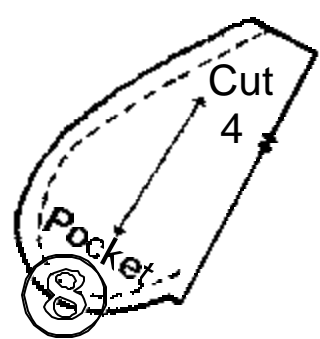
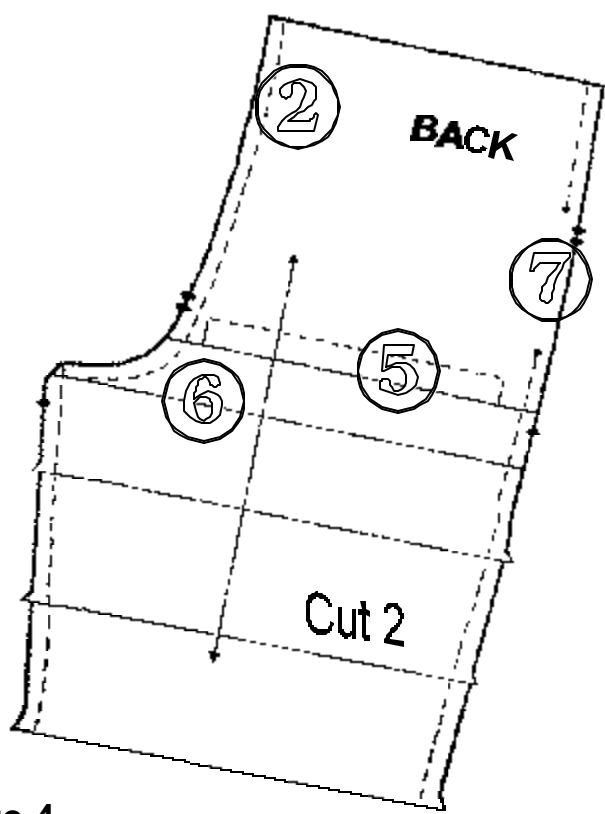
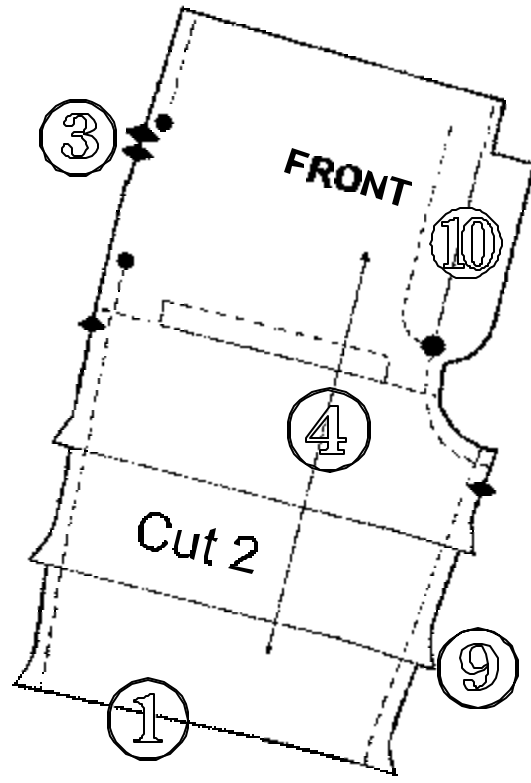

How Good a Director are You?

Pattern layout means knowing what direction the fabric should be folded and successfully laying out the pattern pieces in the right direction.

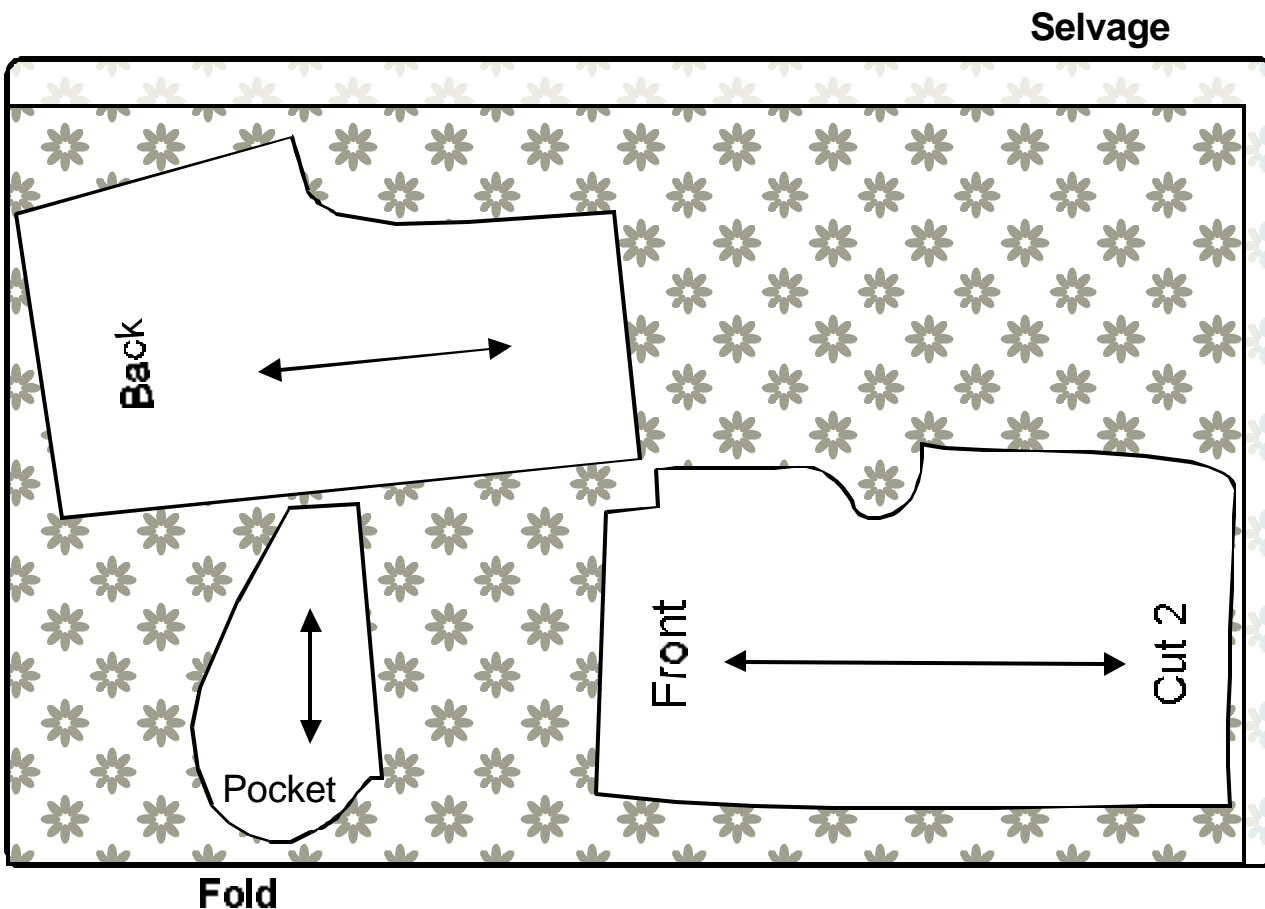

There are three mistakes in the jam's layout above. What are they?

1. _____

2. _____

3. _____

Act 1: Sew Some JAMS!

Props and Equipment You Will Need:

- ✓ pattern
- ✓ sewing machine
- ✓ thread
- ✓ pins
- ✓ scissors
- ✓ fabric
- ✓ iron
- ✓ elastic
- ✓ measuring tape

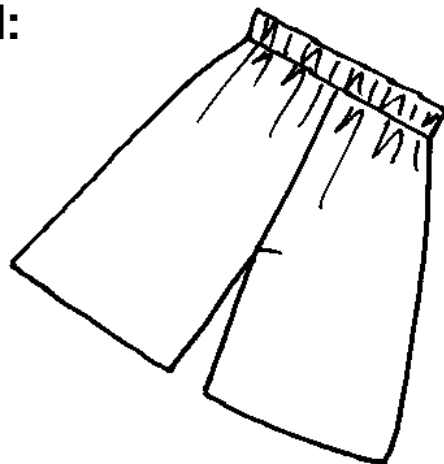

What You Do:

1. Select a pattern and fabric you like.
2. Take your measurements and purchase the needed materials.
3. Wash fabric and fold for layout.
4. Lay out pattern pieces on fabric, pin, cut, and mark.
5. Place one front to one back with right sides together. Pin inside leg seams.
6. Stitch at $\frac{5}{8}$ inch. Press seam open.
7. Pin side seam with right sides together. Remove pins as you stitch. Press seam open.
8. Repeat steps 5 through 7 for the other leg.
9. Turn one leg wrong side out. Place second leg inside this one with right sides together.
10. Pin curved seam (crotch). Stitch at $\frac{5}{8}$ inch. On every curved area, stitch again at $\frac{1}{2}$ inch. Trim to $\frac{1}{4}$ inch. Pull inside out.
11. Fold down for casing. Stitch, leaving 1 inch opening to insert elastic. Pull elastic through. Lap ends of elastic and stitch. Stitch one inch opening.
12. Fold up hem. Pin. Stitch.
13. Press and your jams are ready to wear on your next trip to the movies!

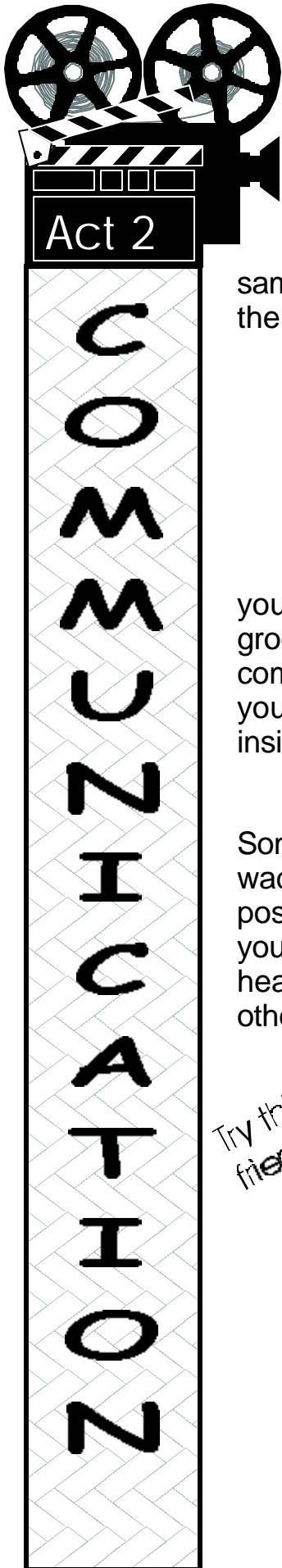

The Spotlight's on You!

The spotlight's on you when in front of the camera. The same is true each day. How you communicate yourself involves the total you...

- how you look
- how you carry and care for your body
- how you act

Your clothing tells many things about yourself, but the way you stand, sit and walk also communicates to others. Good grooming and your actions and manner toward others also communicate. This communication of yourself happens whether you are thinking about it or not. You will get to know yourself better, inside and out, in the following activities.

Isn't it fun to sit in a public place and watch people going by? Some folks slouch; others seem as if they are flying by. Some waddle; others scurry; some trot; others stomp along. Really good posture means being lined up with smooth body movements. If you're well lined up, the three heavy sections of your body - your head, chest section, and hips - should nicely balance one over the other.

Try this with your friends and family!

Play Posture Charades!

- Create a list of descriptive words you communicate through your nonverbal body actions.
- Cut apart the list and place in a container.
- Divide into teams and draw for a "charade".
- Act it out and let others guess.

...Acting The Part

Good posture needs to be a part of your act everyday. Good posture makes you look and feel better in every way. Good posture doesn't mean a stiff, "stand-at-attention" position, but is a body that stands, sits or walks in perfect balance.

Try standing with your body, head, chest and hip sections balanced one over the other. This will help your muscles fall in line and work smoothly as you move. It also helps your internal organs grow and work most effectively.

Practice good posture everyday. Your clothes will look better on you and you'll feel better, too.

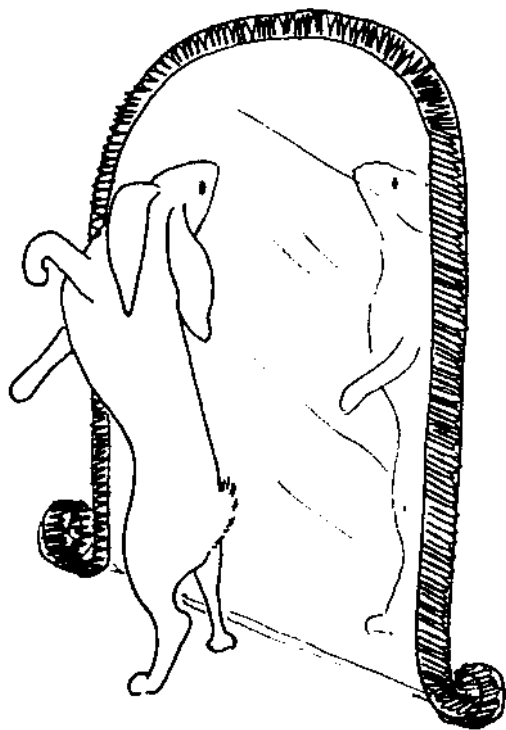



How Is Your Posture?

	Good	Needs Improving
Head High		
Shoulder Blades Flat		
Chest Up		
Stomach In		
Buttocks Under		

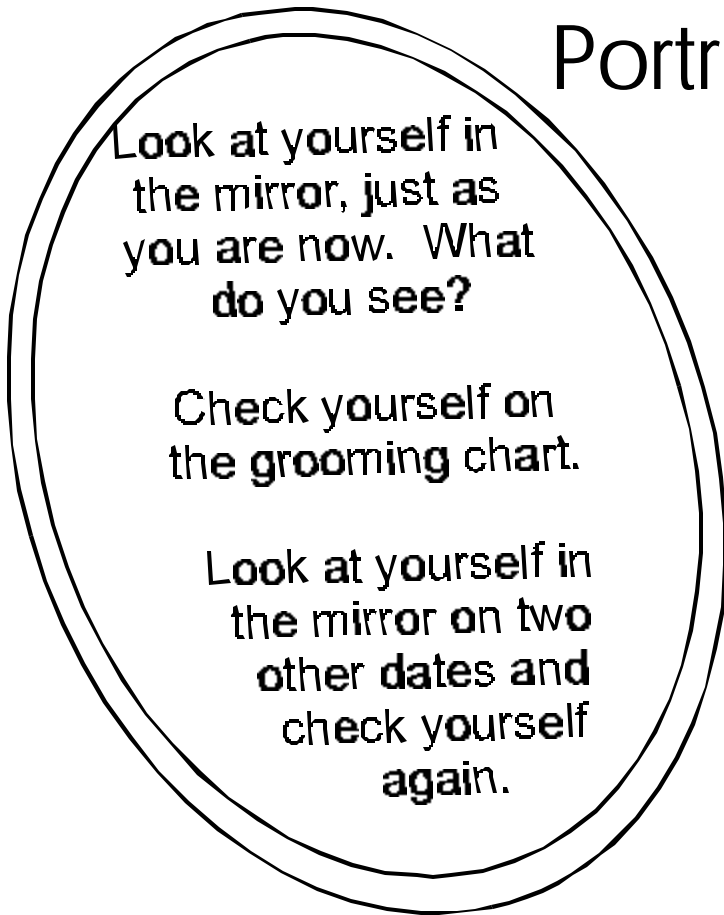
Portraits of Myself



Record the Dates 			
How Do You Rate?	yes/no	yes/no	yes/no
Hair combed?			
Face clean?			
Hair clean?			
Neck and ears clean?			
Hands and nails clean?			
Teeth brushed?			
Bath/shower today or yesterday?			
Clean clothes?			
Clothes neat?			
Shoes clean or polished?			
A smile? 			

Good grooming is necessary whether on a movie set or in real life! Good grooming is a habit learned by practice. Habits are something you do regularly without even thinking about it.

Going to bed at the same time each night is a habit. So is biting finger nails...a *bad* habit. Hanging up your clean clothes is a *good* habit.

List some of your GOOD grooming habits you want to maintain:

List some of your BAD grooming habits you want to improve:

Clean and Neat...Head to Feet!

Good grooming means making yourself as neat and clean as can be.

Setting Up A Schedule...for Personal Care

<i>Grooming Practices I Plan To Do:</i>	<i>Several times A Day</i>	<i>Once a Day</i>	<i>Twice a Day</i>	<i>Once a Week</i>	<i>Once a Month</i>
<i>Brush teeth</i>	✓				

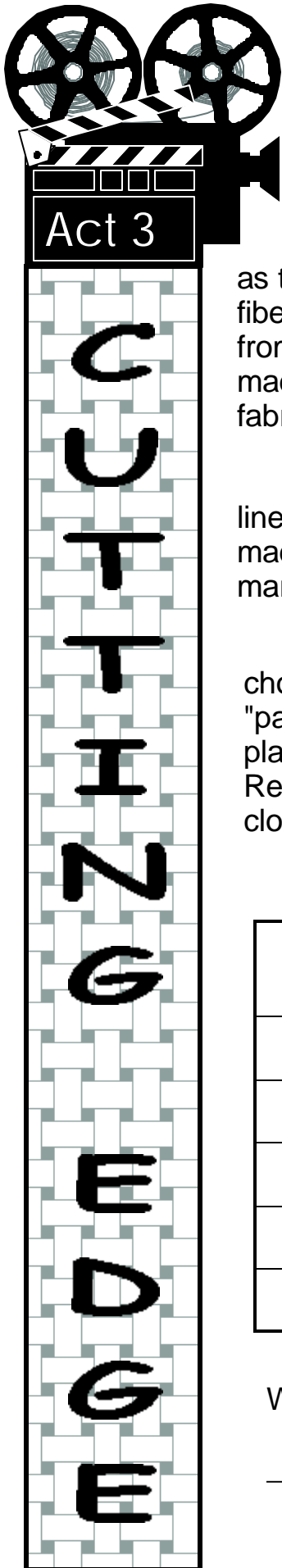

Of Fibers & Fabrics

The "Cutting Edge" of fibers and fabrics can be as exciting as the latest technology in the movie business! New and stronger fibers and fabrics are engineered each year. Fabrics are made from fibers that come from either nature or chemical labs (man-made fibers). Some fabrics are made from both, these are called fabric blends.

Natural fibers come from either plants or animals. Cotton and linen are plant fibers, while wool and silk come from animals. Man-made fibers belong to certain "generic" names or "families". Some man-made fibers are: nylon; polyester; rayon; acrylic and acetate.

Actors or actresses are chosen if they fit a "part." When choosing clothing it's important to choose the best fabric for the "part," too. See if you can find which fibers are used to make play/sport clothes and which ones are used for dressy clothes. Read the label on your clothes (or other family members' clothes) or use a catalog.

Garment	Type of Fiber by Percent (%)	Where Do I Wear It? or Type of Garment

What did you discover? _____



A What's Its Name?

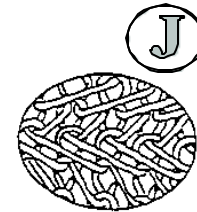
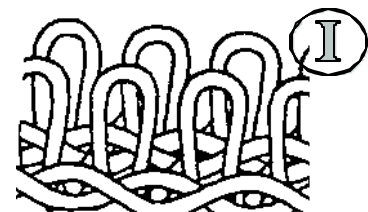
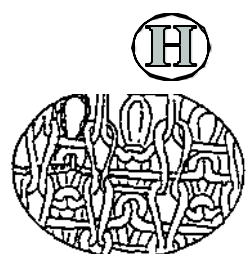
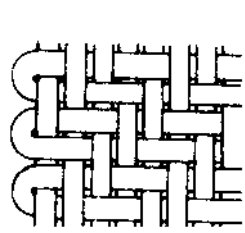
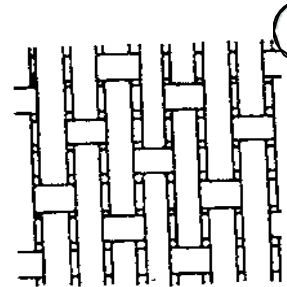
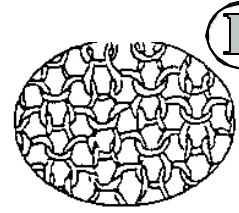
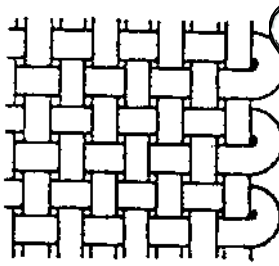
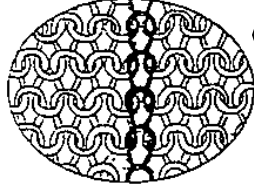
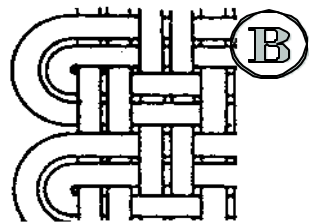
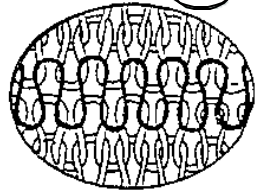

Just as actors have "stage names," how fabrics are woven or knitted determine their name. Look at the illustrations of fabric construction. Match it to its name by writing in the letter.

- ___ 1. Plain weave ___ 2. Pile weave ___ 3. Twill weave
- ___ 4. Weft knit ___ 5. Basket weave ___ 6. Double knit
- ___ 7. Satin weave ___ 8. Single knit ___ 9. Tricot knit
- ___ 10. Warp knit

The "Ins" and "Outs" Of Fabrics

Some fabrics are made by weaving yarns together. Two types of weaves are the plain weave (one over, one under) and the basket weave (two threads over and under). Let's have some fun weaving by making a coaster!

What You Need:

- ✓ Old denim jeans or denim fabric
- ✓ Fabric scraps
- ✓ Fabric glue, glue gun or sewing machine
- ✓ Scissors
- ✓ Piece of cardboard or foam board
- ✓ Pins or tacks

What You Do:

- Cut 4½ x 4½ inch square from denim.
- Cut slits in the square, leaving ½ inch on each side.
- Cut or tear 1 x 6 inch strips from fabric scraps.
- Pin or tack denim square to board.
- Weave the fabric through the denim using either the plain weave or basket weave.
- After the coaster is complete, glue or stitch the edges.
- Cut off the excess ends of fabric strips.

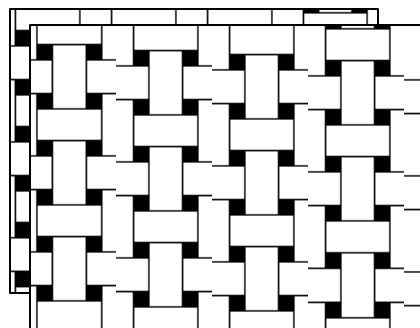
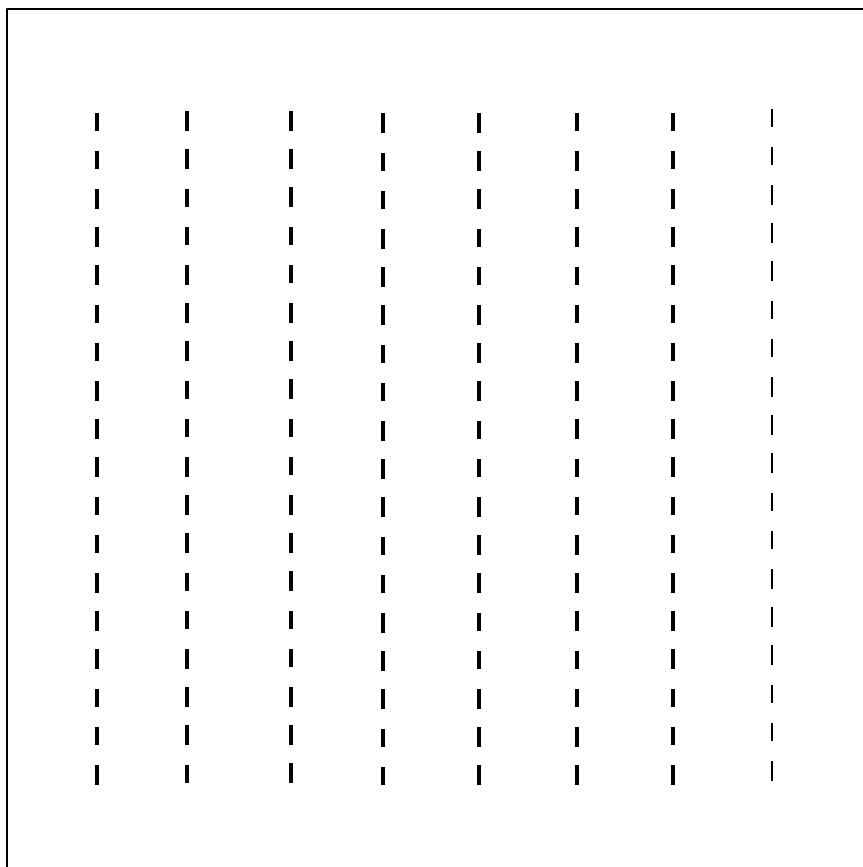

Fabric Fun Experiments

By looking at a variety of fabrics and doing some experimenting with them, you can learn important facts that will help you make wise choices when you buy or make your clothes. One of the facts we will explore in this experiment is “draping”. The “drape” of a fabric is how it falls or looks when made into a garment. Try this test and see if you can predict the best fabrics for different clothing styles.

What You Need:

- ✓ Empty cardboard roll from paper towels or toilet tissues
- ✓ Clean sheet of paper
- ✓ Pencil
- ✓ Fabric scraps or old clothing

What You Do:

- If using a paper towel roll, cut it down to about 5 inches in length.
- Cut out a circle at least 6 inches in diameter from the fabric. (Use a compass or trace around a bowl.)
- Stand the tube upon a clean sheet of paper.
- Place the circle of fabric over the tube and let it fall naturally.
- Carefully draw around the outline the fabric makes as it lies naturally.
- You will have a drawing something like one of these.

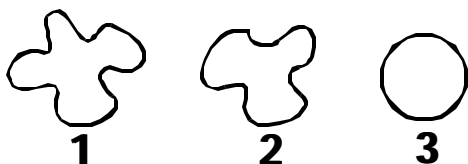

Fabric Drape

How well did your fabric drape? Circle which drawing it was closest to.



Draw its shape here.

This drawing will help you imagine how the fabric will drape or fall when made into a garment.

Fabric 1 is soft and it hangs close to the tube. Fabrics like this will be good for garments with soft, flowing lines, and those with lots of gathers.

Fabric 2 has gentle curves. It would be best for garments that are not too “body-hugging.”

Fabric 3 has lots of support and is stiffer than the others. This is best used in garments that stand away from the body, not soft gathered styles.

After trying this several times, you can recognize what fabrics are best for what styles. When buying garments, you can do tests in the store by draping fabric over your fist.

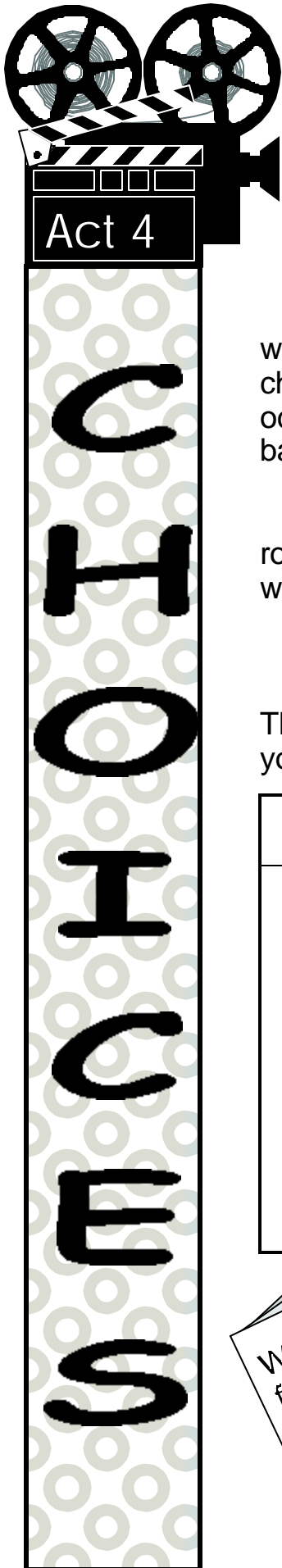

... Be Yourself!

Your clothes tell others many things about you, such as, what you do, what you like, or where you are going. You often choose your clothing to match a “role” (what you do) or a special occasion. You may have several roles, such as student, 4-H'er, band member, or sports team member.

Just as actors in movies, you too may dress differently for roles you have. Have you ever felt uncomfortable when you weren't dressed “right” for certain activities or roles?

Think about the roles you have and the choices of clothing that you wear.

Roles I Have	Clothes I Wear

What about other family members...do they have certain clothes to wear for different roles?

Choices Collage

Create a clothing collage. Cut and paste pictures of clothing that tell what people do.

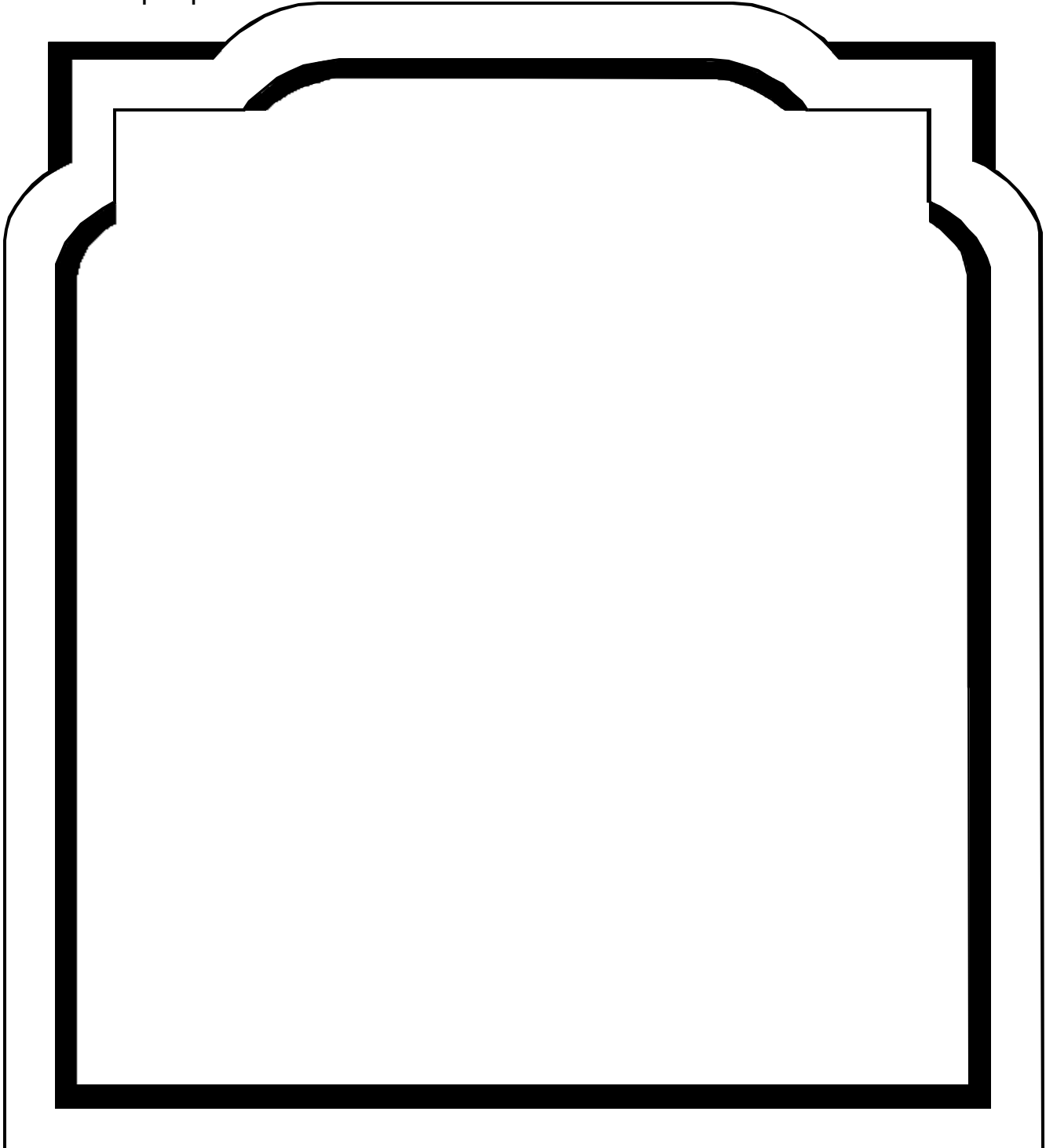

Fashion Count Fun

Another factor that affects what we choose to wear is the current clothing styles. One way to tell what styles are in fashion is to observe what people are wearing. A good way to observe people in everyday clothing is to go to a busy place such as a department store, a grocery store or the mall.

Try This!

- Go to a crowded place.
- For one hour observe what people are wearing.
- You may want to focus on kids your age, adults or older citizens. Or go as a team and have someone observe one group while you observe another to compare notes!
- Tally the items you see people wearing to determine the latest fashion trends in your area!
- Be sure to record the number of people you observed.

Date: _____
 Place: _____
 Time: (from) _____ (to) _____
 Weather: _____

Boys	
Shorts	
Pants	
Jeans	
T-Shirts	
Woven Shirts	
Socks	
Shoes: <i>Athletic</i>	
<i>Casual</i>	
Vests	
Sweats	
Sweaters/Jackets	
Hats/Caps	
Total People Counted	_____

Girls	
Skirts: <i>Long</i>	
<i>Short</i>	
Shorts: <i>Long</i>	
<i>Short</i>	
T-Shirts	
Collared Shirts	
Shoes: <i>Athletic</i>	
<i>Dressy</i>	
<i>Casual</i>	
Vests	
Jeans	
Pants/Slacks	
Sweats	
Hats/Caps	
Other:	
Total People Counted	_____

What were the top three fashion trends that you saw?

Color Plays A Leading Role!

Have you ever noticed that an outfit can really look good on one person and bad on another? Have you ever been complimented on a particular outfit? Often the color of the outfit plays a role in your total look. Cool and warm colors look differently on people based on their skin tone.

Are You Cool or Warm?

Check to see what your skin tone is by looking on the waist or midriff area of your body.

List 3 items of clothing you wear in your color zone!

Cool skin tones have blue or pink undertones. Does the skin have a blue/white cast or blue/black cast? If so, your skin tones are cool.

Warm skin tones have golden or yellow undertones. If you have golden tones, then, your skin tone is warm.

Try This!

What You Will Need:

- red, yellow, blue, white, black watercolor paints
- water
- brushes
- paper
- small dish for paint palette

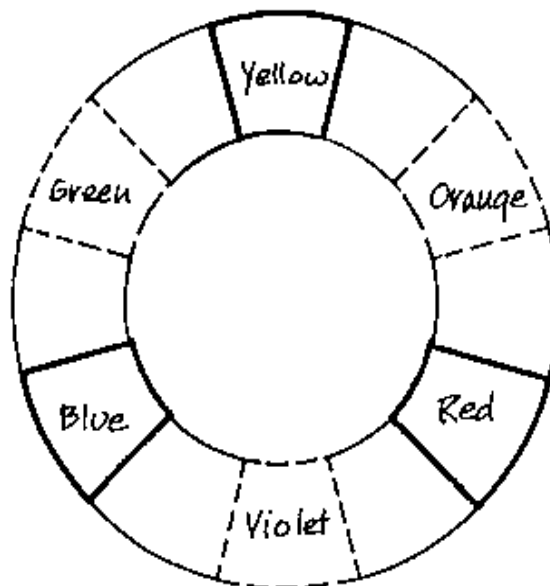

What You Do:

- Mix the three primary colors and paint a "swatch" of each on your paper.
- Add these colors together to get secondary colors of orange, green and violet. Paint swatches of each on your paper.
- Now, experiment with tints and shades by adding white or black to the primary and secondary colors. Paint swatches of a tint and shade of each of the primary colors.
- After paints dry, cut and paste your samples on your color wheel!

Wardrobe Planning

Mixing and matching clothes to come up with a new look for different scenes is the same whether you are at home searching your closet or in the costume room of a movie set! Test your skill in "wardrobe" planning with this activity.

Fill (plaids, patterns, etc.) and color the clothing items on the next page to match clothes in your closet or items you would buy.

**Record your combinations
in each box!**

Now that you've got your wardrobe prepared, see how many different outfits you can make from your wardrobe. Using the numbers beside each item, record the combinations in the boxes to the right.

You can add your own accessories to your basic wardrobe.

How many different combinations did you achieve?

What made the task easy or difficult?

How well do you mix and match your wardrobe each week?

Very

Some

**Not Very
Well**

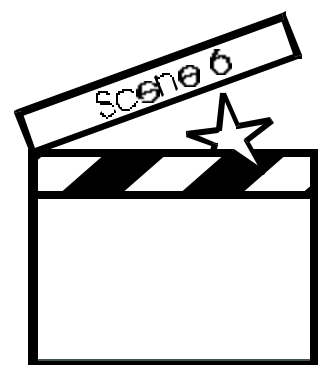
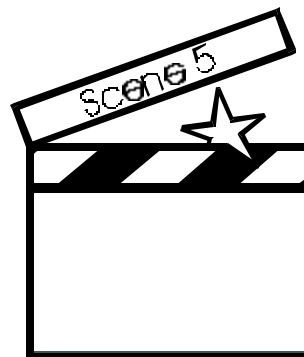
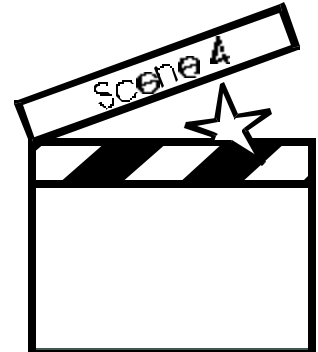
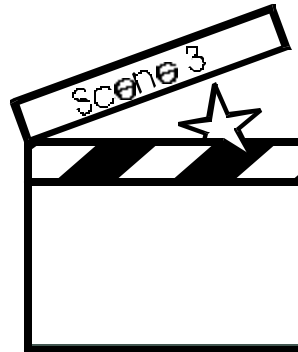
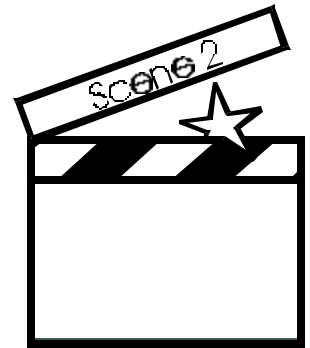
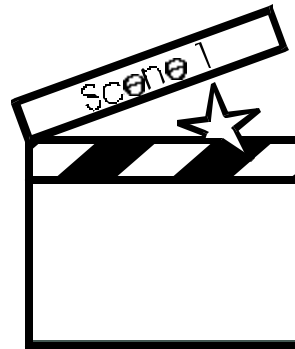

Just like a great magician...you can make your clothes grow before your eyes with this new skill!!

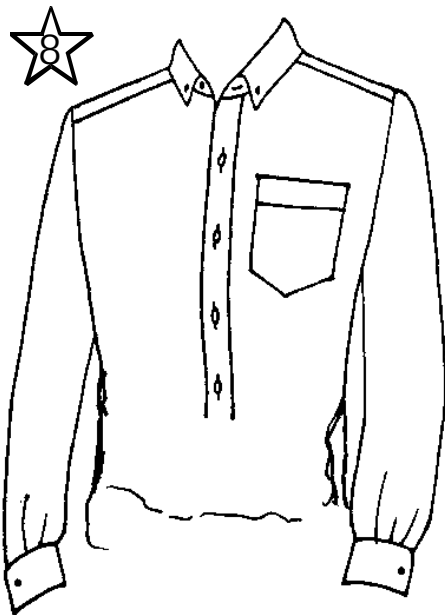
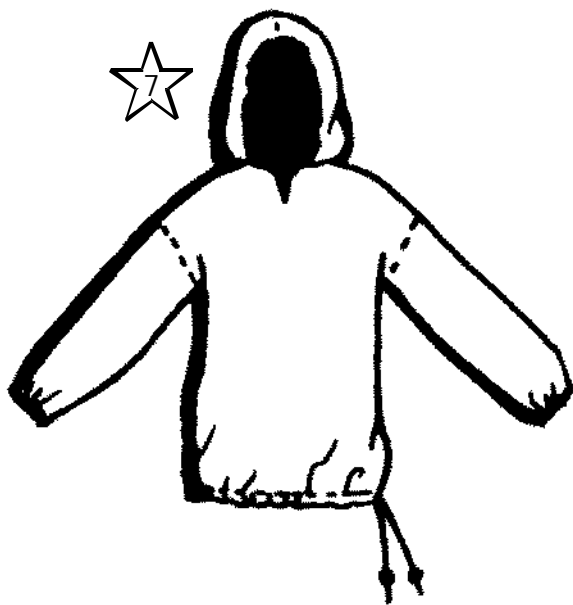
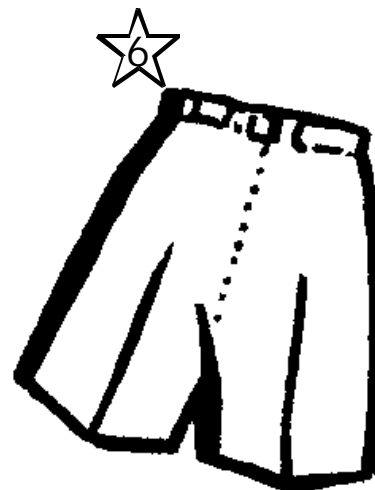
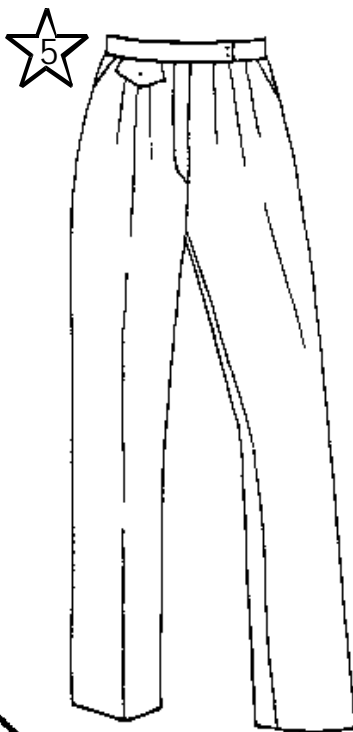
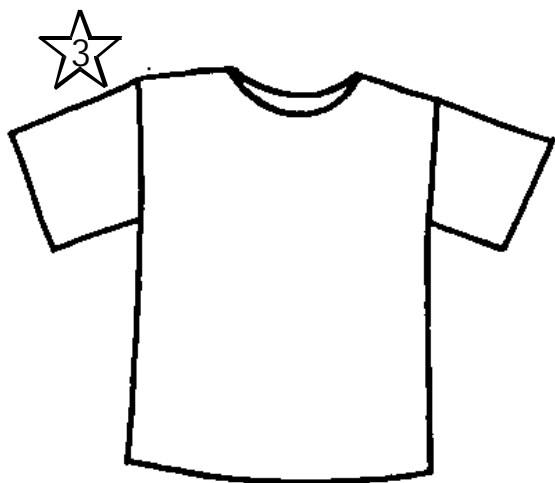
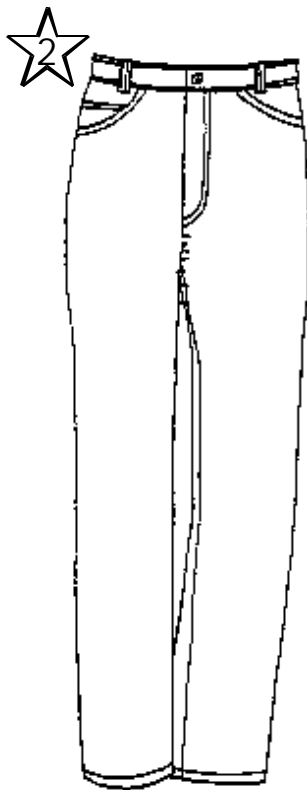



Act 5

...Be a Super Shopper

Everyone is a consumer. Every time you go to a movie or purchase an item, you are a consumer. Consumers have rights and responsibilities. It is important to know what you should do to be a good consumer.

As a good consumer of clothing and textiles there are things you should consider. Fabric quality, care, fit and price are a few. Where do you find most of this information? The label, of course. It is your right to know this information.

Practicing good consumerism will help you to be more satisfied with the items you purchase.

RIGHTS AND RESPONSIBILITIES

Place a star ★ beside your rights and a ✓ beside your responsibilities as a good consumer.

- _____ _____ To expect the garment you purchase to be durable.
- _____ _____ To be in a safe environment while you shop.
- _____ _____ To select your purchases carefully.
- _____ _____ To report complaints.
- _____ _____ To know the fiber content of an item.
- _____ _____ To carefully follow care instructions.
- _____ _____ To carefully handle merchandise in the store.
- _____ _____ To know the price of an item.
- _____ _____ To be polite.

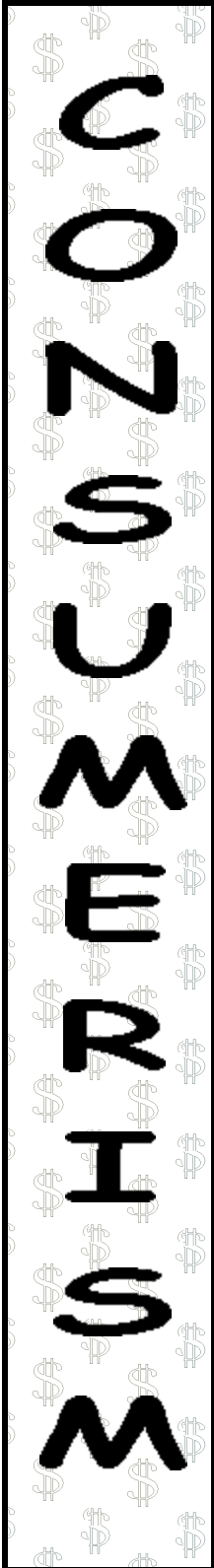

...Label Ratings!

Every item you wear has a label on it somewhere. Take a look at the clothes you are wearing---can you find all the labels? Check your shoes, too! There are two types of clothing labels: those permanently attached and "hangtags." Hangtags are cardboard tags that hang on strings attached to garments when you buy them. They are not permanent and not required by law. They give you some additional information such as price, fabric finishes, fabric types (i.e..stretch), guarantees, and brand names.

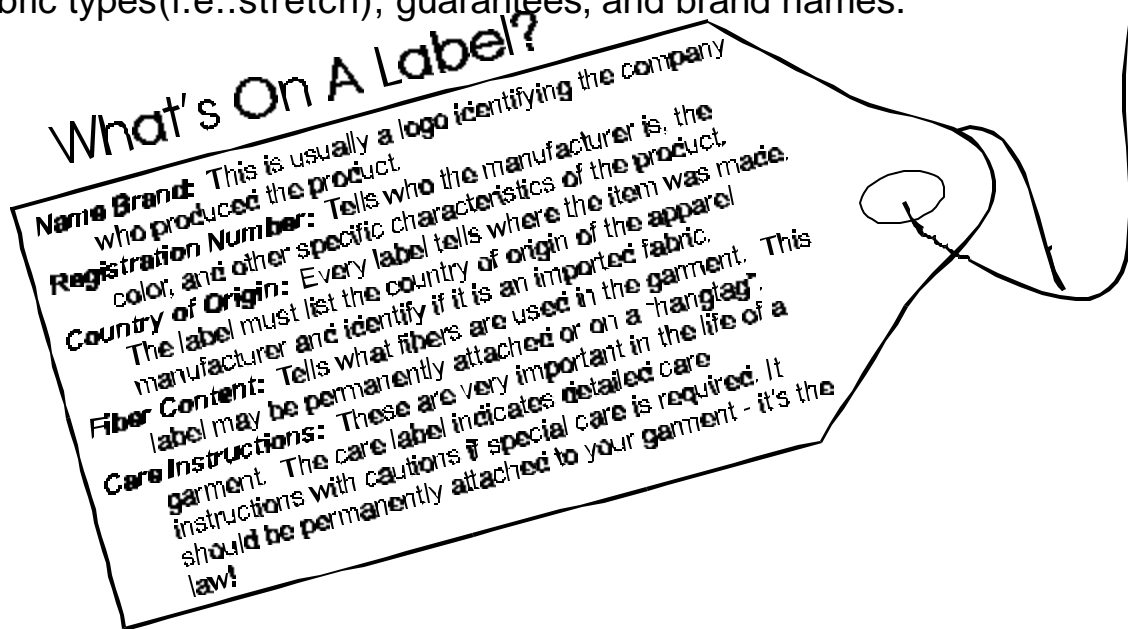

Rate the Label!

- PG13-Has all the information
- PG-Pretty good-has most of the information; easy to find
- G - Good - has some of the information; hard to find
- R - Really bad - Doesn't have the care information!
- X - No labels - Do NOT Buy!

Do This!

- Visit a local store that sells clothing.
- Choose 5 garments of the same type and rate the labels!

Garment	Rating
1	
2	
3	
4	
5	

How Good a Critic Are You?

Being a critic of good clothing choices when shopping is a great skill. There are many factors to take into account: quality of fabric and garment construction; complete label information; fit; and cost. The store or brand name does not always guarantee these. Conduct your own investigation and become a great clothing critic!

Let's Go Shopping!

Go to 2 different stores.
Choose 1 department store
and 1 discount store.

At each store choose 2
garments that are almost
identical.

Read the labels, examine the
garments and try on each.

Record your findings in the
chart below.

Did high price always equal high quality?
What about low price? Explain what you
found.

Were certain brands more expensive
than others? Which ones?

Which of the four garments is the best
buy?

To Check for Quality, ask Yourself:
Good Fabric?
Well-Made?
Labeled Properly?

Store	Garment	Brand	Cost	Fit	Quality
1					
2					

Shopping Etiquette

There are certain rules you must follow when you go to the movies: no talking, be polite to fellow moviegoers; don't bring in outside food or drink; throw garbage in trash cans; keep ticket stub and be polite to the usher. It is the same when you go shopping. In order to get good service you must follow certain rules.

Listed below are five things you should do when shopping and five things you shouldn't do.

Do's and Don'ts

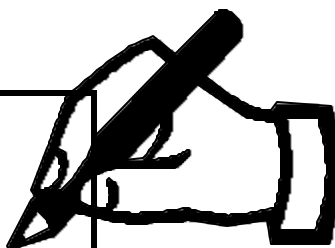

Presented a receipt for a return.

Tried on garment for fit.

Asked store policy on returns BEFORE purchasing garment.

Read care label before purchasing.

Was careful not to stain garments while trying them on.

Tried garments on and left them on the dressing room floor.

Bought a garment without trying it on.

Was rude to the store clerk.

Brought food or drink into the store.

Took too many items into the dressing room.

Go to a store and see how many customers do the things on the list. Try to find at least one example for each of the items listed.





...It's Important

Act 6

C
A
R
E

There certainly would not be any exciting capers on film to watch if proper care is not taken in the storage and handling of film. The same is true for your clothing care. Caring for your clothing is important and it shows! Washing your clothes properly can make them last longer and also helps them look nicer. Caring for your clothing includes correctly mending and storing them, packing them when traveling, treating stains and caring for them according to the care instructions on the label.

The care instructions for any garment can be found on the label, just like the care of film is located on its container. It is very important to follow these instructions properly to maintain the quality of the items.





Seek out the laundry basket at home. Examine the clothing to determine how to launder.

Garment Description	Fiber Content	Care Instructions	Stain Check

LAUNDRY Game

The purpose of this game is to stay on the board as long as possible. The player who reaches the finish LAST is the winner. Players throw a die in turn, and follow the directions on the square where they land. Unless routed on a detour, players should follow the main path. You can cut out small playing pieces that look like garments.

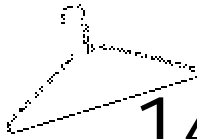
<p>Didn't mend hole in jeans before washing. Now it is even bigger.</p> <p>Advance to 3 1</p>	<p>Measured detergent before adding it to washer.</p> <p>Wait 2 turns 2</p>	 <p>3</p>	<p>Put bath towel in wrong load; everything covered with lint.</p> <p>Advance to 7 4</p>
<p>Start</p>			<p>Sorted clothes by color before washing.</p> <p>Wait 1 turn 5</p>
<p>Hung some clothes to dry to save energy.</p> <p>Go back to 3 19</p>	<p>Finish</p> 		<p>Forgot to pre-spot chocolate stain; now it is there forever.</p> <p>Advance to 7 6</p>
<p>18</p>	<p>Gave it to my little sister.</p> <p>Go back to 10 a</p>		 <p>7</p>
<p>Left clothes in hot dryer too long; now they are wrinkled.</p> <p>Advance to 18 17</p>	<p>Threw it away.</p> <p>Wait 1 turn, Advance to FINISH b</p>		<p>Used low water setting when washing a few items.</p> <p>Go back to 7 8</p>
<p>Put shirt in hot dryer and it came out 2 sizes smaller. Follow detour on next turn. 16</p>	<p>Cut it up and made a pillow.</p> <p>Go back to 14 c</p>		<p>Put red shirt in wash with white clothes; everything came out pink.</p> <p>Advance to 14 9</p>
<p>Sorted washed clothes by temperature before drying. Wait 3 turns 15</p>			<p>10</p>
 <p>14</p>	<p>Remembered to check pockets of jeans before washing.</p> <p>Go back to 10 13</p>	<p>Washed vest that should have been dry cleaned and ruined it.</p> <p>Advance to FINISH 12</p>	<p>Read care label before washing new shirt.</p> <p>Wait 2 turns 11</p>

Going, Going, GONE!

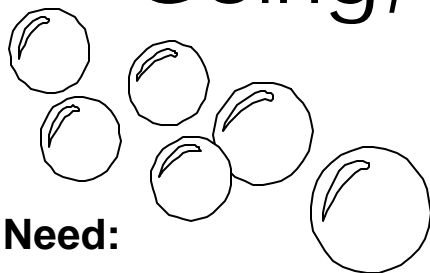

What You Need:

- ✓ 2 brands of granular detergent
- ✓ 1 brand of liquid detergent
- ✓ measuring spoons
- ✓ measuring cups
- ✓ 6 clean, clear jars with tight lids

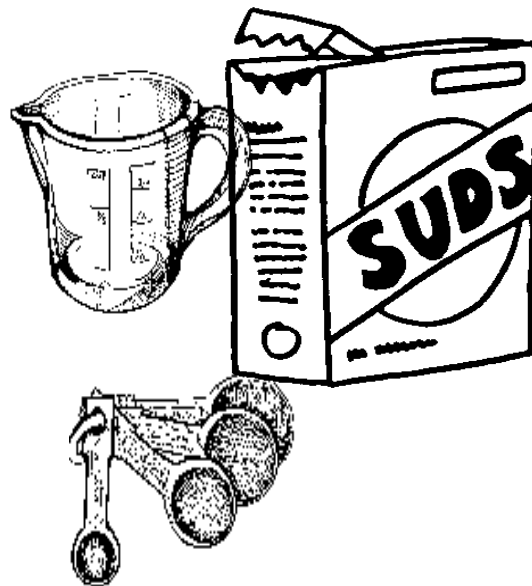

What You Do:

- 1 Prepare labels for each jar with each brand and water temperature.
- 1 Fill 3 jars with 1 cup of cold water.



COLD WATER

- 1 Put 2 Tablespoons of each brand in one jar of cold water.



HOT WATER

- 1 Fill remaining three jars with hot water.
- 1 Put 2 Tablespoons of each brand in one jar of hot water.

- 1 Place lids on and shake each jar five times.

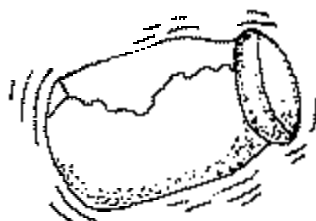

- 1 Record your observations.

...Which One Is Best?

Record a “yes” or “no” under expected results, if you think the detergent will dissolve in that water temperature. Or, rate 1-2-3 the ones you think will be Best (1) - Better (2) - Okay (3)!

Detergent	Temperature	Expected Results Yes or No?	Observations What Happened?
Granular Detergent	Hot		
	Cold		
Granular Detergent	Hot		
	Cold		
Liquid Detergent	Hot		
	Cold		

Which granular detergent was the most soluble (disappeared!)?

Was the granular detergent more soluble in or water?
Hot Cold

Was the liquid detergent more soluble in or water?
Hot Cold

Which one would you recommend? _____

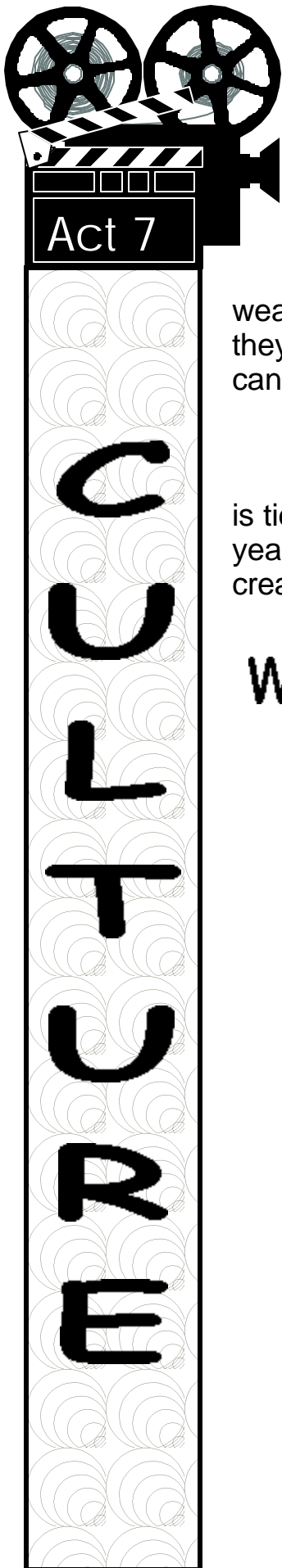

...Zoom in on Culture

Culture can be easily identified by the clothing a person wears. This identity is displayed by the items worn and the way they are worn. Fabric designs and decorative treatment of fabric can often identify cultures.

Fabric designs come from all over the world. One of these is tie-dyeing. Tie-dyeing has been common in Africa and India for years. Experiment with tie-dyeing and see what designs you can create!

What You Need:

- ✓ T-shirt
- ✓ Rubber bands
- ✓ Fabric dye, salt and bowls
or
fabric spray dye
- ✓ Newspaper
- ✓ Water
- ✓ Hanger

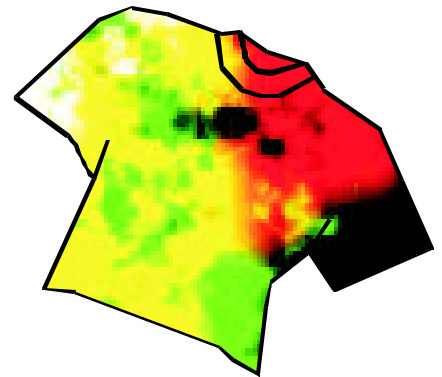

Tie-Dyeing Fun!

What You Do:

- Spread newspapers over table or work area.
- Prepare the fabric dye in bowls of water according to directions on package. If using the fabric sprays read instructions for steps to follow.
- Lay T-shirt flat. Pull the shirt from the center up toward you. Place rubber bands in 2 or 3 places.
- Dye each section separately.
- If the dye directions say to, rinse the shirt in salt water solution to help colors set. Do now.
- Drape over hanger. Allow shirt to dry with rubber bands in place.
- Remove rubber bands. Rinse. Let dry.
- Wear your T-shirt proudly!

TRY THESE!

Tie-dyed Circle:

Place fabric over index and middle finger. Gather fabric together at base of finger tying it with rubber bands as shown.



Tie-dyed Sunbursts:

Gather fabric over fingers as you did for the circle. Secure at base with rubber band. Using an additional rubber band to wrap the entire fabric finger unevenly but tightly.

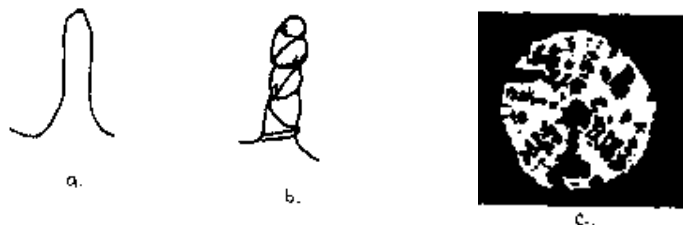

Tie-dyed Stripes:

Using chalk and a ruler, mark a series of parallel lines where you want your stripes to be. Fold the fabric back and forth along the lines forming pleats. Bind the pleats with rubber bands as shown.

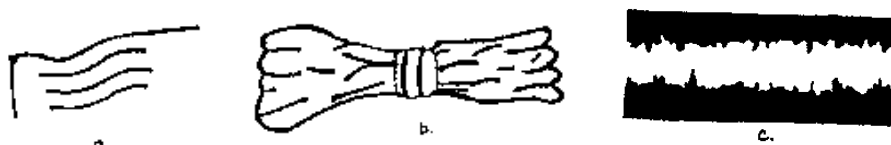

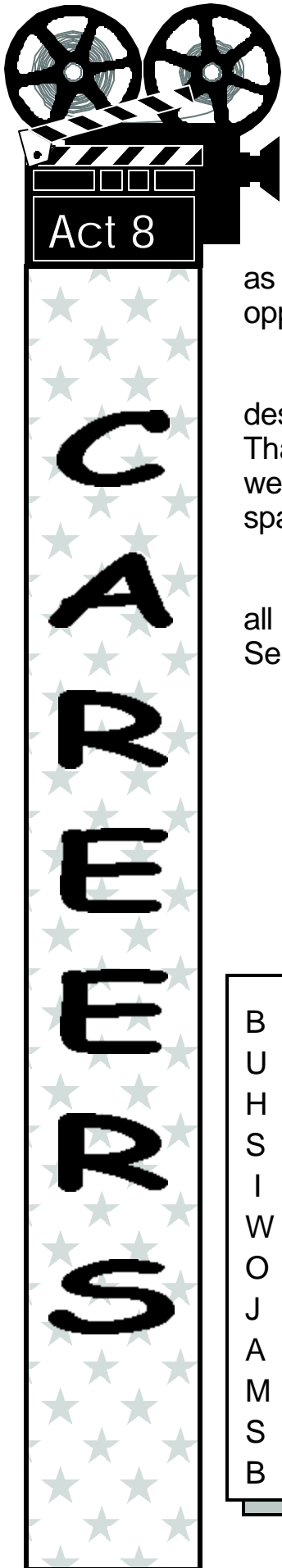

FOCUS On Careers

It's never too early to start exploring what you'd like to do as a future job or career. You may be surprised at the many job opportunities in the field of Clothing and Textiles.

Careers range from the creative arts of advertising and design, to the science and technology used in textile chemistry. That's right, someone designs everything from the clothes you wear and the label on them, to the fabrics on chairs or the next space suit!

Let's focus on a few of the possibilities. See if you can find all these Clothing and Textile related careers in the Career Search!

A Career Search

- | | |
|-------------|--------------------|
| Chemist | Sorter |
| Dry Cleaner | Interior Decorator |
| Sales Clerk | Pattern Maker |
| Artist | Tailor |
| Engineer | Researcher |
| Buyer | Spotter |

B	I	N	T	E	R	I	O	R	D	E	C	O	R	A	T	O	R
U	T	S	O	A	E	N	D	S	R	Z	O	F	I	W	C	M	O
H	E	P	G	H	I	B	A	X	Y	L	U	Y	S	W	Q	V	R
S	E	O	H	J	E	L	S	R	C	H	E	M	I	S	T	Y	E
I	N	T	R	O	P	Q	O	B	L	H	F	Y	A	N	L	H	S
W	G	T	F	V	M	K	E	R	E	N	S	O	R	T	E	R	E
O	I	E	B	J	L	A	Y	G	A	B	P	Y	H	A	W	S	A
J	N	R	P	A	T	T	E	R	N	M	A	K	E	R	G	A	R
A	E	Y	L	F	N	W	S	P	E	A	T	L	O	T	R	N	C
M	E	P	J	L	C	B	X	E	R	O	T	W	G	I	Z	E	H
S	R	E	S	A	L	E	S	C	L	E	R	K	A	S	L	O	E
B	U	Y	E	R	O	U	B	L	O	N	F	C	O	T	T	E	R

...Career Explorations

Think of all the ads you see on television, magazines, and catalogs. What about all the fashion designers, photographers and illustrators...would you like to explore these careers? Choose one of these creative occupations and create a design of your own on this page.

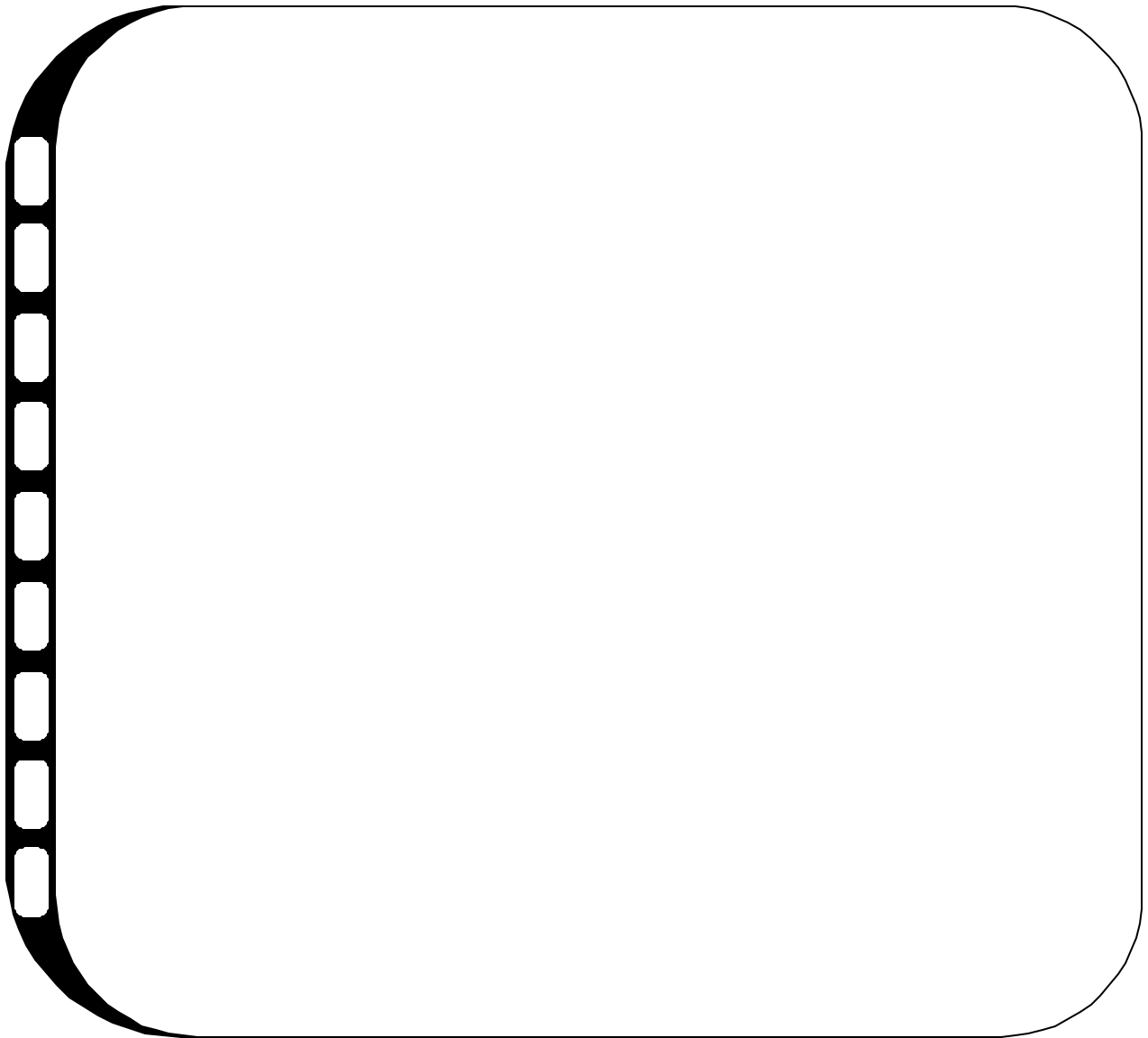

Career Choice: _____

Career Capers...

How would you like to produce your own "interview show" on local career opportunities in clothing and textiles? To do this, someone must first research the topic.

Investigate the job or career possibilities in the clothing and textile industry in your local area. You can use the local newspaper or yellow pages in the phonebook.

See how many different jobs in your area related to clothing and textiles you can find. Think about businesses other than places that sell clothes.

For examples look for:

- dry cleaners
- alterations shops
- garment manufacturers, or
- fabric stores

Another important step to good career planning and investigation has to do with yourself. What kinds of things do you like to do?

In what kinds of places would you like to live?

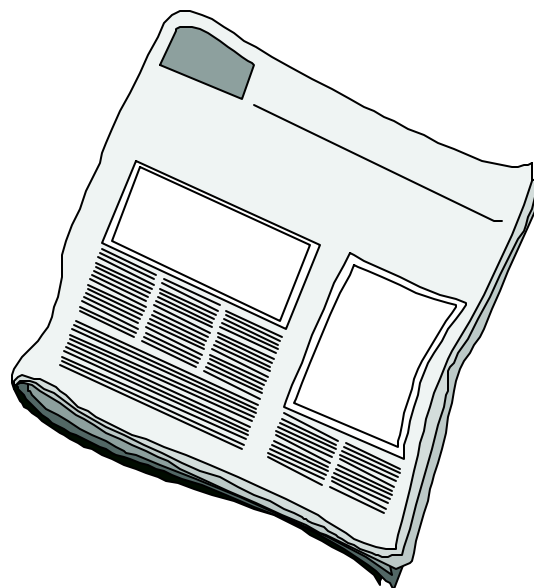

What kind of people do you like working with or around?

How would you like to dress?

Think of answers to these questions as you explore career possibilities. Next, think of words that describe your talents, personality traits and educational ambitions (creative, self-motivated, outgoing) and make a list.

...A Personal Portfolio

Using the list of words that describe you, create your own advertisement for yourself.



It's A Rap!

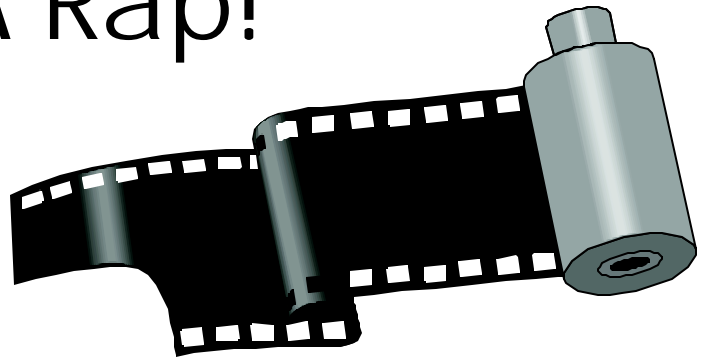

How did you do?

List the items you made:

What did you learn?

Check the new words you learned doing this project.

- | | | |
|-----------------|----------------|---------------------------|
| _____ grainline | _____ fiber | _____ Registration Number |
| _____ notch | _____ staple | _____ label |
| _____ tint | _____ weave | _____ granular detergent |
| _____ shade | _____ consumer | _____ presser foot |

Write a paragraph describing your favorite activity that you completed:

Chart Your Progress

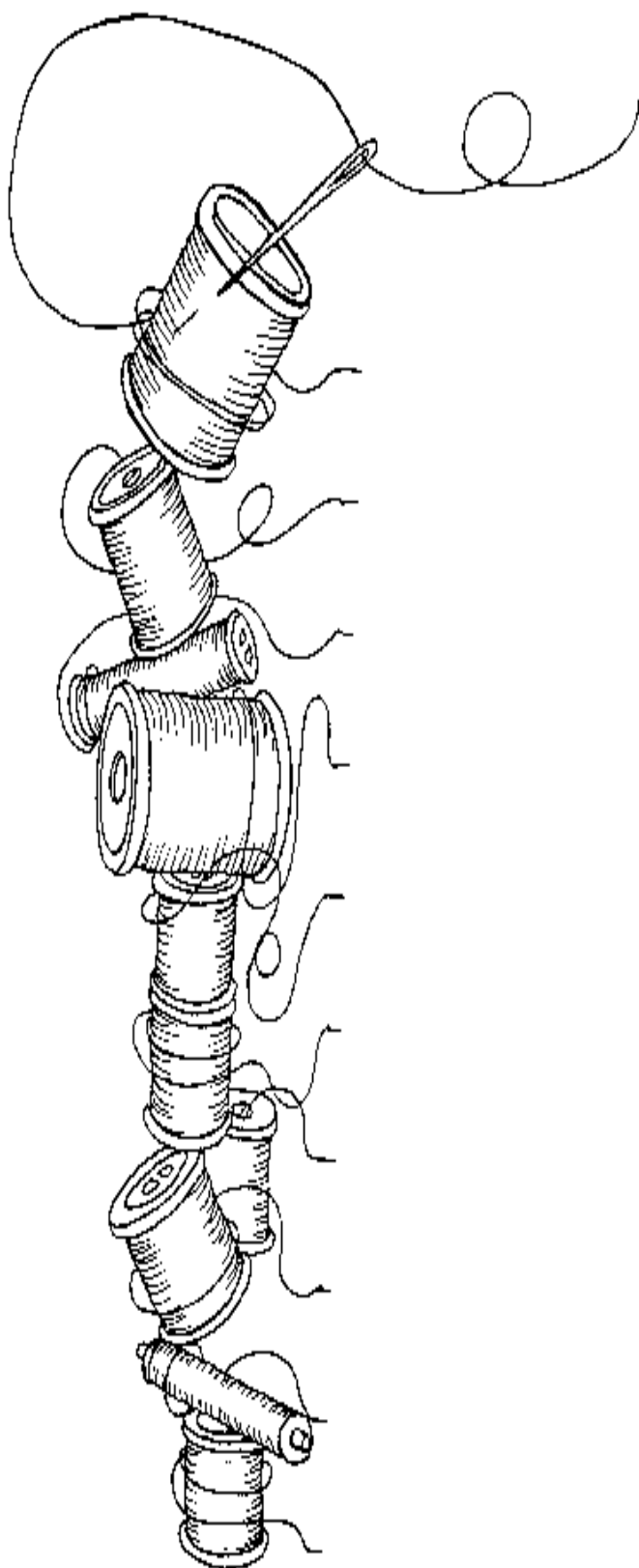

Did you...

- Sew a pair of jams?
- Learn how to read and use a pattern?
- Check your posture and plot good grooming moves?
- Experiment with color tints and shades?
- Identify different fibers and fabrics?
- Count fashions to determine fads and trends?
- Identify your rights and responsibilities as a consumer?
- Experiment with laundry detergent?
- Tie-dye an item for yourself or a friend?
- Discover new career opportunities in clothing and textiles?

Name _____

Club or
School _____

Leader _____

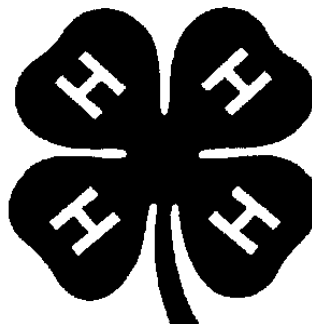

4-H Club Motto
"To make the best better"

4-H Club Pledge
I pledge

my head to clearer thinking,
my heart to greater loyalty,
my hands to larger service, and
my health to better living, for
my club, my community,
my country, and my world.

4-H Club Colors
Green and White



Authors: M. Joy Cantrell, Associate Professor and 4-H Youth Development Curriculum Specialist, and R. Nadine Hackler, Professor, Clothing and Textiles, Department of Family, Youth and Community Sciences, University of Florida Institute of Food and Agricultural Sciences.

Graphic Design/Illustrations: Angela Framton and Eva Oakes, Department of Family, Youth and Community Sciences, University of Florida Institute of Food and Agricultural Sciences.

Design Team: Shirley Clark, Gadsden County; Mary Williams, Nassau County; Dot Allen Brandt, Citrus County; Judy Butterfield, Clay County; Susan Nigg, Volunteer, Manatee County; Mary Beth Salisbury, Osceola County; and Becky Conley, Volunteer, Osceola County.

COOPERATIVE EXTENSION SERVICE, UNIVERSITY OF FLORIDA, INSTITUTE OF FOOD AND AGRICULTURE SCIENCES, Christine Taylor Waddill, Director, in cooperation with the United States Department of Agriculture, publishes this information to further the purpose of the May 8 and June 30, 1914 Acts of Congress; and is authorized to provide research, educational information and other services only to individuals and institutions that function without regard to race, color, age, sex, handicap or national origin. The information in this publication is available in alternate formats. Information on copies for purchase is available from Publications Distribution Center, University of Florida, P.O. Box 110011, Gainesville, FL 32611-0011. Information about alternate formats is available from Educational Media and Services, University of Florida, P.O. Box 110810, Gainesville, FL 32611-0810. This information was published May 1996, Florida Cooperative Extension Service. Reprinted March 1998; reviewed June 2002.