

USING A COGENERATION FACILITY

To Illustrate Engineering Practice to Lower-Level Students

ROBERT P. HESKETH, C. STEWART SLATER
Rowan University • Glassboro, NJ 08028-1701

Almost every university has a power plant facility that is an excellent resource for students of engineering processes and equipment. These physical plants contain many unit operations, such as heat exchangers, combustors, turbines, and boiler water-treatment systems that may include membrane devices! The systems are equipped with pumps, compressors, fans, pipes, atomizers, tanks, finned boiler tubes, inner-wall transfer surfaces, valves, etc. In addition, a modern facility includes a data-acquisition system to obtain data to control the plant consisting of orifice plates, pressure transducers, thermocouples, level gauges, and vibration meters. Concentration measurements are made using NDIR gas analyzers for CO, CO₂ and total hydrocarbons. And oxygen is measured using paramagnetic analyzers and NO_x using chemiluminescence. Concentration measurements are also made of impurities in the boiler water. These plants are a rich source of engineering examples that are readily accessible to engineering students.

At Rowan University, we use our cogeneration facility in our freshman and sophomore chemical engineering courses. In the freshman year we introduce our students to measurement devices, process flow diagrams, and process simulation. This is accomplished in the freshman engineering course in a three-week module on process measurements.

ROWAN ENGINEERING CLINICS

The Rowan engineering faculty are taking a leadership role by using innovative methods of teaching and learning, as recommended by ASEE,^[1] to better prepare students for entry into a rapidly changing and highly competitive marketplace. Key program features include

- ▶ *Inter- and multidisciplinary education created through collaborative laboratory and course work*
- ▶ *Stressing teamwork as the necessary framework for solving complex problems*

- ▶ *Incorporation of state-of-the-art technologies throughout the curricula*
- ▶ *Creation of continuous opportunities for technical communication.*

To best meet these objectives, the four engineering programs of chemical, civil, electrical, and mechanical have a common engineering clinic throughout their program of study. In addition to the engineering clinic, they share a common first year of courses. Our first three classes of entering freshmen are between 101 and 115 students with an average SAT score of 1252 and who graduated in the top 14% of their high school class.

The primary goal of Rowan University's freshman engineering course is to immerse students in multidisciplinary projects that teach engineering principles using the theme of engineering measurements in both laboratory and real-world settings. Many freshman programs focus on either a design

Robert Hesketh is Associate Professor of Chemical Engineering at Rowan University. He received his BS in 1982 from the University of Illinois and his PhD from the University of Delaware in 1987. After his PhD he conducted research at the University of Cambridge, England. His teaching and research interests are in reaction engineering, freshman engineering, and mass transfer.

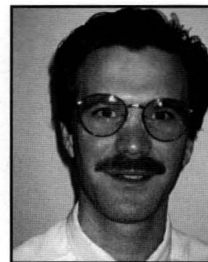

C. Stewart Slater is Professor and Chair of Chemical Engineering at Rowan University. He received his BS, MS, and PhD from Rutgers University. His teaching and research interests are in separation and purification technology, laboratory development, and investigating novel processes for interdisciplinary fields such as biotechnology and environmental engineering. He has written over 70 papers and several book chapters.

project or a series of discipline-specific experiments that may not be cohesively integrated. Some institutions have used traditional discipline-specific laboratory experiments at the freshman level,^[2] while others engage students in discipline-specific freshman engineering design projects.^[3] One of the NSF coalitions, ECSEL, has major efforts in freshman design that have been widely reported.^[4,5] At Rowan, freshman engineers are introduced to industrial problems through a series of four modules and interactive lectures on problem solving, safety, and ethics. In this paper, we will discuss a portion of the process engineering module that uses the vehicle of a cogeneration plant.

Freshmen can be overwhelmed when introduced to real engineering processes, and it is important to have well-defined objectives. They need to understand that they are only being *introduced* to the problems and are not expected to know all of the engineering principles of the processes. Our overall objectives for the fall-semester freshman engineering clinic are

- **Engineering Measurements** Students will understand and apply the concepts of accuracy, precision, resolution, and linearity; calibrate devices; have a knowledge of the basics of data acquisition; analyze a problem and select appropriate measurement devices for actual engineering processes.
- **Engineering Communication** Students will produce plots using Excel to illustrate engineering principles; use PowerPoint for presentations; use word processing for reports of actual engineering problems. Students will develop the ability to work in multidisciplinary teams, have effective meetings, and use a problem-solving strategy on real engineering problems.
- **Engineering Fundamentals** Students will convert units, examine equations for dimensional homogeneity; use engineering equations, apply basic concepts (*e.g.*, hydrostatic pressure, Hooke's law, Ohm's law) applied to actual engineering problems.

Four measurement modules are employed in this freshman engineering clinic: manufacturing, structural, process, and electrical engineering. Spatial measurements and measurement fundamentals are introduced to freshman engineering students as they fabricate a MAG-type flashlight from an aluminum rod. Several structural measurements are shown to the students using a bridge module. Students first survey a bridge site, conduct strain measurements on a model bridge, and simulate the bridge.

The university cogeneration plant is used to show the use of temperature, pressure, flow, and concentration measurements. The students tour the cogeneration plant and record data of temperature, pressure, and flowrate of the water in the cogeneration unit. They then return to the computer laboratory and simulate two heat exchangers, using their readings, and perform hand calculations for homework. This is followed by two weeks of experiments using temperature, pressure, and flowrate devices seen in the cogeneration plant.

The final module has the students construct a temperature alarm circuit and investigate the use of C++ programming in measurements. Thus, the clinic focuses on measurements in the field and also in traditional laboratory settings. Field trips tend to excite students by breaking down the monotony of being indoors and helping them prepare for realistic engineering measurements.

PROCESS MEASUREMENTS MODULE

The process measurements module presents a "day in the life of an engineer" to freshman engineering students. A problem is posed to students requiring them to visit the university cogeneration facility. At this site both traditional (gauges and thermometers) and data acquisition measurement systems are employed to monitor the steam and electricity generation process. This laboratory and homework session is followed by

These [cogeneration] plants contain many unit operations, such as heat exchangers, combustors, turbines, and boiler water-treatment systems that may include membrane devices! The systems are equipped with pumps, compressors, fans, pipes, atomizers, tanks, finned boiler tubes, inner-wall transfer surfaces, valves, etc. In addition, a modern facility includes a data-acquisition system to obtain data to control the plant consisting of orifice plates, pressure transducers, thermocouples, level gauges, and vibration meters.

two more laboratory sessions in which students make process measurements using similar equipment to that seen in the cogeneration plant. The module lasts three weeks, with each week having a 1-hour and a 3-hour session.

Preceding the cogeneration site visit, students are given lecture and problem sessions on teamwork, safety, system of units and unit conversions, dimensional homogeneity, and significant figures. On the week of the site visit, the students are given a brief introduction to the cogeneration process and are shown photographs of equipment that they are required to identify on the site visit.

At the completion of this module on the cogeneration facility, freshman students should be able to

- Convert units of simple dimensions.
- Convert units of a variable, such as flowrate.
- Calculate the temperature of saturated steam when given a gauge pressure and an appropriate equation.
- Examine an equation for dimensional homogeneity.
- Obtain measurements of temperature, pressure, and mass flowrate and perform an energy balance on the heat exchangers in the cogeneration system.
- Create a simple heat exchanger network using the chemical process simulator HYSYS.
- Identify from a photograph the following: orifice plate, pressure transducer, thermometer, and pressure gauge.
- Describe the process of cogeneration to a high school student.

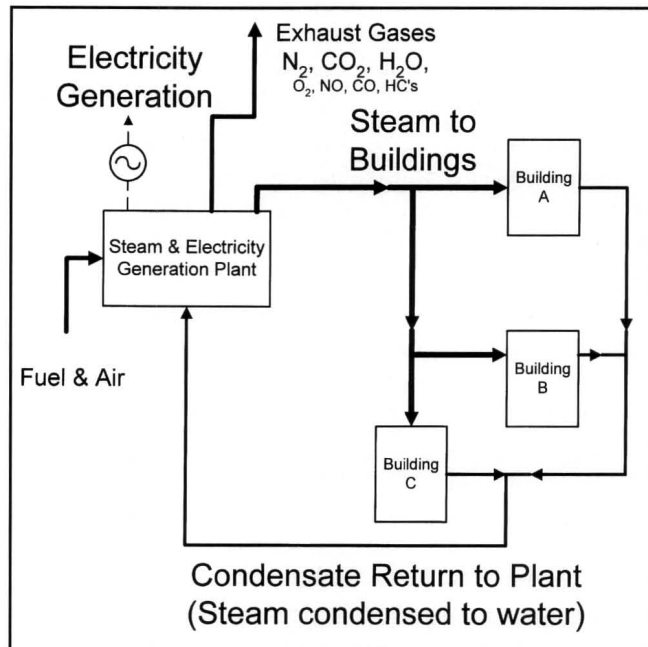

Figure 1. Overall schematic of Rowan University Steam & Electricity Generation

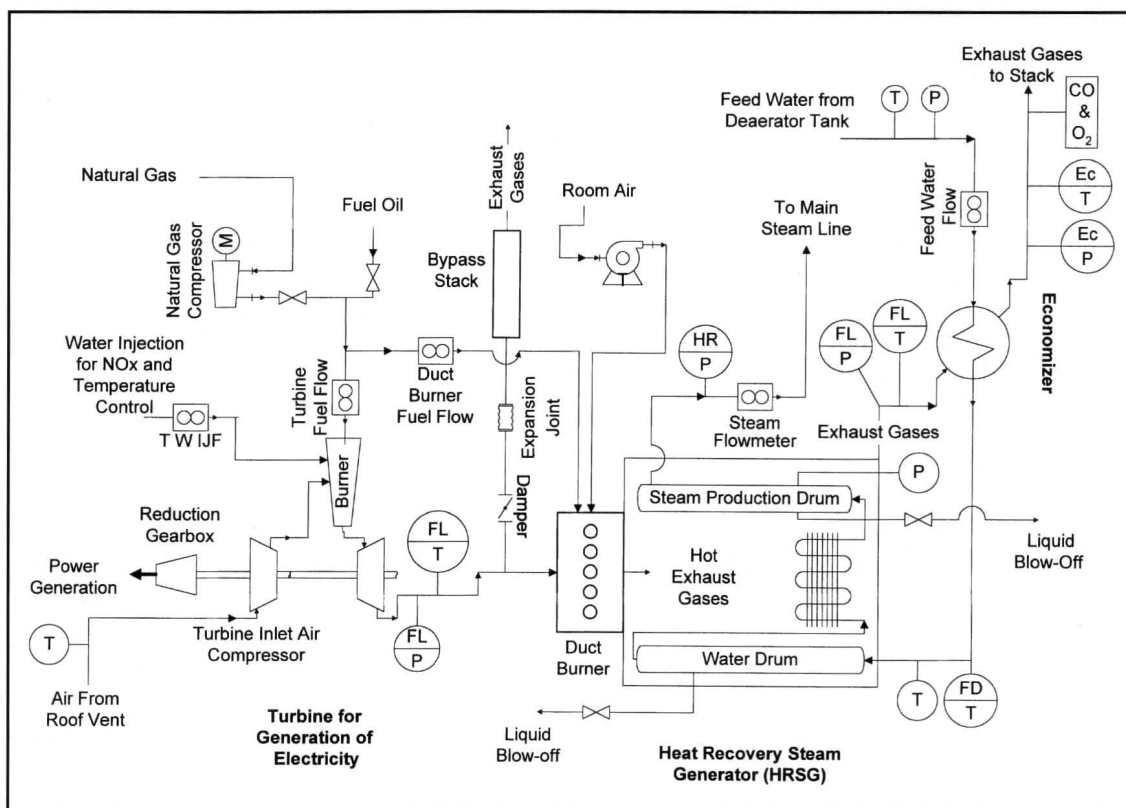

Figure 2. Rowan cogeneration plant fabricated by Energy Recovery International.

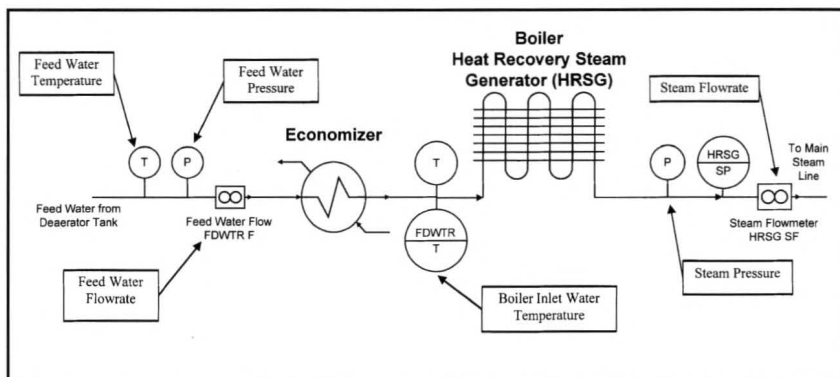

Figure 3. Cogeneration process water flow diagram.

TABLE 1
Plant-Trip Readings

Reading	Reading Value	Units
Feed-water flowrate to cogeneration facility	25.1	1000 lb _m /hr
Steam flowrate from cogeneration facility	21.6	1000 lb _m /hr
Feed-water temperature	216	°F
Feed-water pressure	250	psig
Boiler-inlet water temperature	330	°F
Steam pressure from cogeneration system	150	psig

COGENERATION PLANT INTRODUCTION

Rowan University uses steam for both heating and cooling of its buildings. An additional benefit to the process is the generation of electricity. We explain to the students that the process of electricity and steam generation is called cogeneration. It is obvious to most students how a building is heated with steam using radiators, but it is not obvious how to cool a building with steam! Professors are probably aware that steam is used with absorption refrigeration^[6-8] and we are very pleased to see that one of the best treatises on this subject is in Perry's handbook!^[9]

The overall flow diagram for the use of steam at Rowan University is shown in Figure 1. In the Steam Plant, steam is produced by three conventional boilers and a cogeneration unit. Steam flows through underground pipelines to each of the university buildings, through radiator units or the refrigeration absorption units (air cooling), and then is returned as condensate to the steam plant. In our new engineering building, these units are located on the fourth floor, and we are attempting to modify this laboratory to use this floor for future engineering classes.

An advantage of using this steam plant is that both traditional (gauges and thermometers) and data-acquisition measurement systems are employed. Most of the traditional gauges are for measuring temperature, pressure, and liquid height. At the other end of the spec-

trum is the advanced data-acquisition system, which records 65 channels of information including vibrations, power, voltage, amperage, temperature, pressure, gas, and flowrates. Students are able to see the advantages of using both mechanical gauges and pressure transducers. Also given throughout this module is the cost of various types of measurement equipment.

SITE VISIT

Students are given the process flow diagram shown in Figure 2 to illustrate the complexity of a relatively small portion of the steam plant pertaining to the cogeneration. Figure 3 is also given to the students and shows only the steam production side of the cogeneration unit. Using this relatively simple figure, students relate their knowledge of boiling water to that of steam production in a cogeneration unit. The students obtain readings (shown in Table 1) from every device marked in Figure 3. Obtaining readings in the plant turns the plant trip into an active learning experience. They need to obtain information from this trip that they will use immediately in the simulation and homework. In addition, a quiz is given showing photographs of some of the common measurement equipment. A map of the cogeneration facility is also given to the students to show placement of the equipment and measurement devices in the building. Using these figures, students are guided by professors and upper-division chemical engineering students through the combustion process and the production of steam and electricity.

These readings are used as input to a chemical process simulation package, HYSYS, and as input to a set of hand

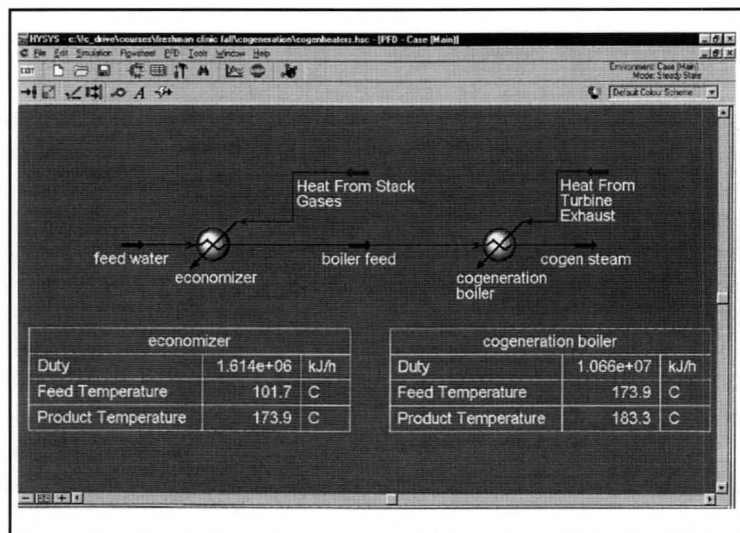

Figure 4. HYSYS-generated process flow diagram with summary tables.

calculations for a homework assignment. In both the HYSYS simulation and homework assignment, the students determine the heat duties of two heat exchangers.

Upon completion of this short site visit, students have seen actual process equipment and obtained readings from a real process. The students now have motivation to perform engineering unit conversions and calculations described in the next two sections.

PROCESS SIMULATION

At the end of the site visit, students return immediately to the computer room and are led through a simulation program of the two heat exchangers. The students follow a self-paced tutorial on using HYSYS to simulate their process. They start the computer program and select the ASME steam tables as the thermodynamic property package. Next they simulate the two heat exchangers as heaters. After installing each heater, they enter the readings obtained in the plant. From this simulation, they obtain the temperature of saturated steam and the values of the heat duties of both heaters. A process flow diagram, generated by HYSYS, of these two heaters is shown in Figure 4.

After completing this laboratory, students have experienced two of the activities in the "day in the life of an engineer." They have visited an actual plant and then have returned to the computer to simulate a portion of this process.

HOMEWORK

For homework, students must calculate by hand the heat duties on both heat exchangers and the temperature of the saturated steam. In this assignment, they must show all unit conversions and calculations, and all equations must be dimensionally homogeneous. To aid the students in these calculations, the answers to most of their calculations are obtained from the HYSYS simulation printouts. These printouts contain the plant readings in both the English and SI system of units. So the student will obtain agreement between the heat duty on the economizer, but will not get an exact agreement with the simulated boiler heat duty.

It is very important to give all the necessary equations to the freshmen with a clear explanation of the variables. We have also found that the description or name of each measurement must be identical to both the HYSYS variable names

and the equation variable names. Finally, the variable names must be explicitly given in each equation. For example, instead of T in heat capacity, heat capacity expressions must be given for all of the temperatures (T_{FW} , T_{steam} , T_{BI}).

The heat capacities of the water vapor and liquid were obtained from empirical correlations based on the ASME steam tables, which are valid in the range $373 \leq T \leq 470$ K. In each of these equations, the units for each constant are explicitly shown. This allows the freshman to determine if each equation is dimensionally homogeneous.

$$C_p^{FW} = 4788.26 \frac{J}{kgK} - 3.4297 \frac{J}{kgK^2} T_{FW} + 4.885 \times 10^{-3} \frac{J}{kgK^3} (T_{FW})^2 \quad (1)$$

$$\hat{H}_{FW} = C_p^{FW} (T_{FW} - 273.16 K) \quad (2)$$

The temperature of saturated steam is calculated as

$$\frac{1}{T_{steam}} = -2.075 \times 10^{-4} \frac{1}{K} \ln \left(\frac{P_{steam}}{1.01325 \times 10^5 Pa} \right) + 2.683 \times 10^{-3} \frac{1}{K} \quad (3)$$

An enthalpy balance on each heat exchanger is calculated from

$$\hat{H}_{FW} \dot{m}_{FW} + Q_{economizer} = \hat{H}_{BI} \dot{m}_{FW} \quad (4)$$

Using the results of these energy balances, an estimate of the energy recovered using the economizer was conducted.

This exercise shows the students the equations that the computer simulation has used to perform engineering calculations. This removes the magic of the computer and shows students the equations that the computer is using in the simulation. After completing this session, the students have the advantage of seeing a process familiar to them (boiling water), performing an advanced computer simulation and then conducting hand calculations of the process.

SECOND AND THIRD WEEK LABORATORY EXPERIMENTS

In the next two laboratory sessions, four experiments are conducted in which the students use equipment similar to that observed in the cogeneration plant. The experiments performed are

- Flowrate measurement: rotameter operation and calibration
- Temperature measurement: immersion heaters
- Pressure measurement: tank efflux and implosion of a 2-L soda bottle

The rotameter operation and tank efflux experiments are classic chemical engineering experiments that have been adapted from Perna.^[2] The tank efflux experiment is modified by adding 3 pressure-measurement devices; a sight gauge, a pressure transducer, and a low-pressure diaphragm gauge. The implosion experiment employs a vacuum pressure gauge, water aspirator, and a 2-L soda bottle to graphically show students the effect of vacuum. The immersion water heater experiment is unique in that domestic electric kettles are employed and the students determine that $dT/dt = Q_{in}/mC_p^{liq}$ for most of the heating process.

SECOND-YEAR EXPERIMENTS USING THE COGENERATION FACILITY

The use of the cogeneration facility continues into the mass and

energy balance course typically taken by students in their second year. Once again, students and professors have an excellent example of real-world mass and energy balances. They learn the approximate compositions of natural gas (fuel oil has a much higher complexity!). Students use their knowledge of oxidation stoichiometry to determine percent excess air and predict outlet concentrations. The students check their answers by comparing them to gas analyzer measurements of oxygen, carbon dioxide, and carbon monoxide. Water produced is usually not measured, but if desired, a gas stream sample can be obtained and either the water condensed or a hygrometer can be used to determine water concentrations. Additionally, mass balances can also be performed on water-treatment systems, including conventional systems and novel membrane systems.

Since these balances are based on actual measurements, students find they are not able to obtain an exact balance on mass and energy. They learn that measurement devices have a limited accuracy and may need to be recalibrated. This was the case the first time we tried to complete a mass balance on the cogeneration fuel stream. Our industrial sponsors are very excited to hear that students conduct balances on actual systems, because many of the problems in a real plant are related to a faulty or out-of-calibration measurement device.

The energy balances on the system were started in the freshman year to see that heat flows from the hot gas to the water. Steam tables are introduced and students use their knowledge of heat capacity and enthalpy gained from chemistry and this course to perform energy balances. In this sophomore course, they now understand the equations that were employed in the freshman engineering module. In the sophomore course students calculate the source of energy production from the combustion reactions. They use standard heats of combustion, fluid flowrates, and chemical compositions to determine outlet gas temperatures. Using measured values, students determine the magnitude of the energy losses in a cogeneration system. They can now understand in more detail why an economizer was added to recover additional energy from the exiting gases. In addition, they can conduct simulations to examine the effect of increasing the surface area of the two heat exchangers on the energy recovered. This brings engineering economics into their coursework!

SAFETY AND ENVIRONMENTAL CONCERNS

The cogeneration plant is also an excellent vehicle to introduce safety, health, and environmental concerns. All freshmen are required to wear safety glasses, hard hats, closed-toe shoes, ear plugs (near turbines), and clothing that covers all limbs. Safety features are shown to students during the introductory lecture and tour, such as guards for rotating equipment and pressure-relief valves. The required EPA monitoring system is shown in which both a continu-

ous paper printout and electronic data are produced. The stack emissions sampling point is readily identified from the catwalk around the stack. Starting freshmen to think about safety and environmental issues in a plant is an excellent reinforcement to their use of laboratory safety.

CONCLUSIONS

The university cogeneration or physical plant is a rich and diverse resource that should be used in many chemical engineering classes. The plant is on campus and is easily accessible. In addition to the time savings in not having to travel to an off-campus site, students can be used as tour guides to minimize group size. Using small groups to tour a facility allows students to hear the tour guide as well as to ask questions about the process. By using real-world examples of engineering, the student's level of understanding and motivation to learn new material increases dramatically. The use of a cogeneration facility in chemical engineering courses is designed to immerse students into multidisciplinary, real-world, laboratory projects that teach engineering principles. Students are excited and challenged by working in real-world settings and are motivated to learn the underlying engineering principles.

ACKNOWLEDGMENTS

Special thanks are given to the physical plant staff headed by Glenn Brewer for help in preparing the cogeneration module, Mark Showers, chemical engineering students, and faculty for giving tours of the facility. Funding for this work was made possible through a grant from the DuPont Educational Aid Foundation.

REFERENCES

1. ASEE, "Engineering Education for a Changing World," Joint project report by the Engineering Deans Council and Corporate Roundtable of the American Society for Engineering Education, Washington, DC (1994)
2. Perna, A., and D. Hanesian, "A Discipline Oriented Freshman Engineering Measurement Laboratory," 1996 ASEE Annual Conference 2326a, Washington, DC., June (1996)
3. McConica, C., "Freshman Design Course for Chemical Engineers," *Chem. Eng. Ed.*, **30**(1), 76 (1996)
4. Dally, J.W., and G.M. Zhang, "A Freshman Engineering Design Course," *J. Eng. Ed.*, **82**(2), 83 (1993)
5. Regan, T.M., and P.A. Minderman, Jr., "Introduction to Engineering Design: A Major Engineering Education Process Improvement," *Proc. 4th World Conf. on Eng. Ed.*, **3**, 243, St. Paul, MN (1995)
6. McQuiston, F.C., and J.D. Parker, *Heating, Ventilating, and Air Conditioning: Analysis and Design*, 4th ed., Wiley, New York, NY, 659 (1994)
7. Moran, M., and H.N. Shapiro, *Fundamentals of Engineering Thermodynamics*, 3rd ed., Wiley, New York, NY, 659 (1996)
8. Smith, J.M., H.C. Van Ness, M.M. Abbott, *Introduction to Chemical Engineering Thermodynamics*, 5th ed., McGraw-Hill, New York, NY, 305 (1996)
9. Perry, R.H., and D. Green, *Perry's Chemical Engineers' Handbook*, 7th ed., 11 (1996) ■