

The object of this column is to enhance our readers' collections of interesting and novel problems in chemical engineering. Problems of the type that can be used to motivate the student by presenting a particular principle in class, or in a new light, or that can be assigned as a novel home problem, are requested, as well as those that are more traditional in nature and that elucidate difficult concepts. Manuscripts should not exceed 14 double-spaced pages and should be accompanied by the originals of any figures or photographs. Please submit them to Professor James O. Wilkes (e-mail: wilkes@umich.edu), Chemical Engineering Department, University of Michigan, Ann Arbor, MI 48109-2136.

# GEOHERMAL COGENERATION: ICELAND'S NESJAVELLIR POWER PLANT

EDWARD M. ROSEN

*EMR Technology Group • Chesterfield, MO 63017*

Energy use in Iceland (population 283,000) is higher per capita than in any other country in the world.<sup>[1]</sup> Some 53.2% of the energy is geothermal, which supplies electricity as well as heated water to swimming pools, fish farms, snow melting, greenhouses, and space heating.

The Nesjavellir Power Plant is a major geothermal facility, supplying both electricity and heated water to Reykjavik. The purpose of this paper is to interest students in geothermal energy, describe a simulation of this plant, and determine the plant's suitability for classroom study.

## PLANT DESCRIPTION

The plant (commissioned in 1998<sup>[2]</sup>) is located near one of the largest high-temperature fields in Iceland.<sup>[3]</sup>

Iceland's high-temperature fields are so rich in gas and minerals that the waters cannot be used directly in the distribution system.<sup>[4]</sup> Its high pressure and thermal energy, however, makes it suitable for heating fresh water and generating electricity.

Ballzus, et. al.,<sup>[2]</sup> provide a plant flow diagram (Figure 1) on which stream flows and temperatures are indicated. Where data is specified, the diagram is modified to include stream

names (e.g. {S1}, {S2}). In addition, the heat exchangers are labeled ({HX1}, {HX2}, {HX3}).

Steam mixed with water {S1} is conveyed from boreholes through collection pipes to the separation station, where the water is separated from the steam. Excess steam and unused water go into a steam exhaust outside the separation station. From the separation station, steam and water proceed by separate pipes to the power plant at a pressure of about 12 bara and a temperature of 190 °C. The steam (after passing through a mist eliminator) is conveyed to steam turbines, where electricity is generated. Each turbine (two of them) produce 30 MW of electricity (MWe).



*Edward M. Rosen received his B.S. and M.S. degrees in chemical engineering from the Illinois Institute of Technology, and his Ph.D. in chemical engineering from the University of Illinois. After retiring from the Monsanto Company, he founded EMR Technology Group. He has served as a trustee of the CACHE Corporation and as a program evaluator for ABET. With E.J. Henley, he is co-author of Material and Energy Balance Computations (Wiley 1969).*

© Copyright ChE Division of ASEE 2008

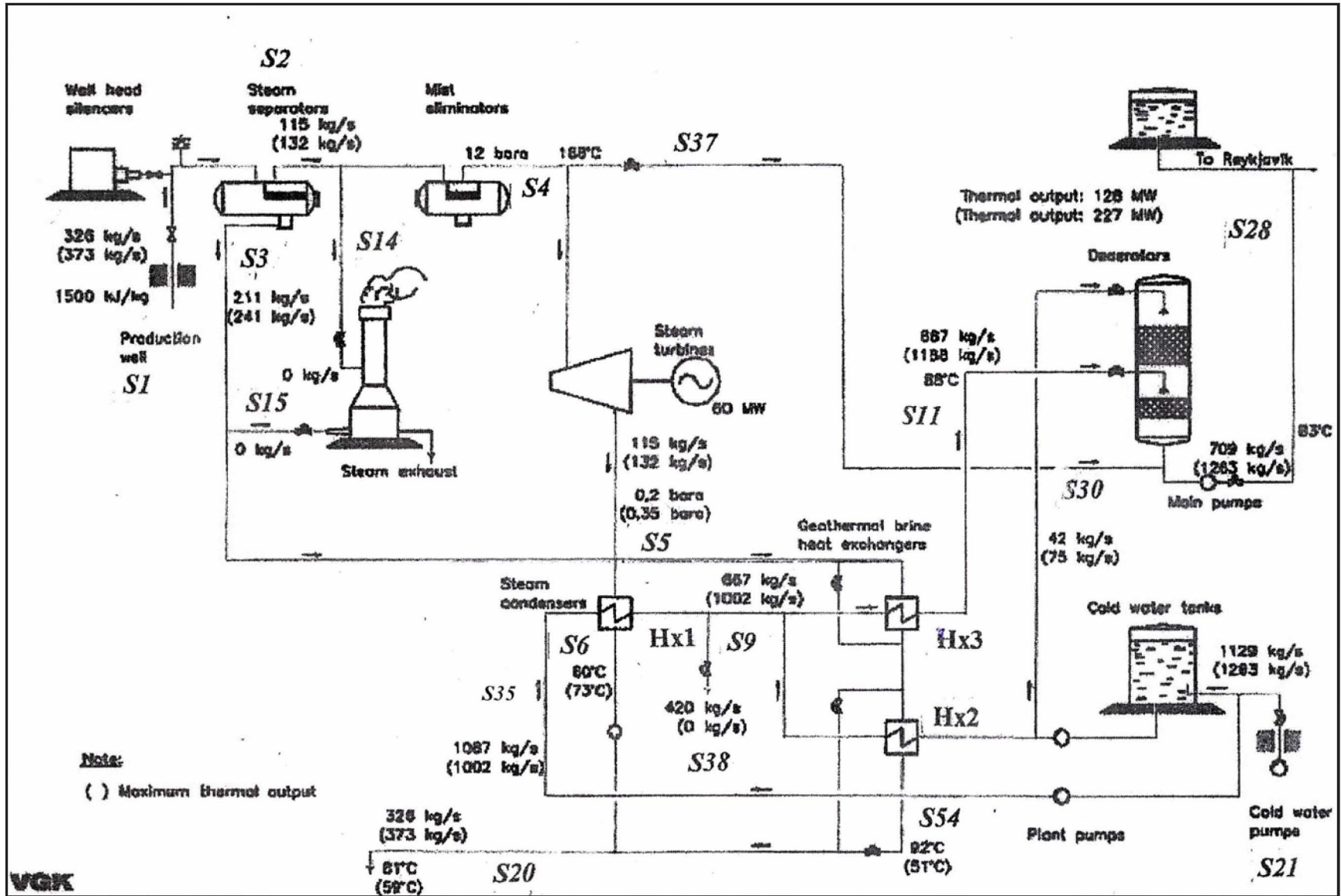

Figure 1. The Nesjavellir Geothermal Plant Process Flow Diagram (Adapted from Ballzus<sup>[2]</sup>), placed vertically to preserve clarity.

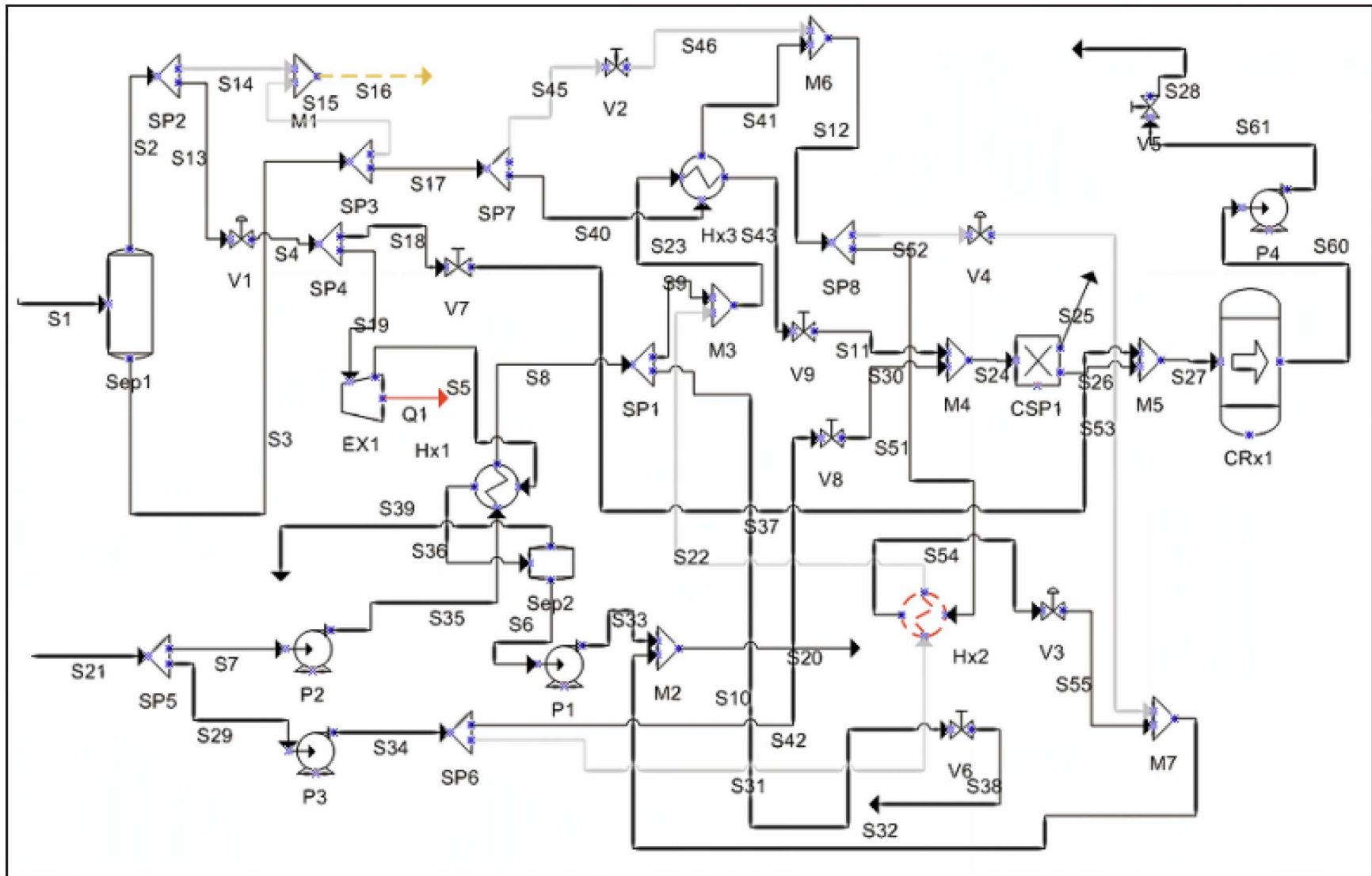

Figure 2. VMGSim Flowchart of Iceland's Nesjavellir Power Plant (placed vertically to preserve clarity).



In the condenser {HX1} the steam exhaust from the turbines is utilized to preheat cold water {S35}. This cold water is then further heated in the heat exchanger {HX3} by the separated geothermal fluid {S3}. (A second heat exchanger {HX2} can be utilized to preheat a portion of the cold water with the separated geothermal fluid from {HX3}. In this simulation, however, {HX2} is not utilized). Since the mineral-rich geothermal fluid causes scaling that coats the heat exchanger pipes, steel particles are allowed to circulate in the stream, impacting against the pipes to remove any scaling as it occurs.<sup>[5]</sup>

The cold water {S21} is saturated with dissolved oxygen that corrodes steel after being heated. To rid of the oxygen, the water is sent to a vacuum deaerator.<sup>[6]</sup> The main flow {S11} enters the central part of the deaerator. The water boils vigorously (due to a vacuum) and sprays over filling material. Steam and gas rise to the top. The steam is condensed through the injection of cold water {S30} before the gas is ejected.

Finally, a very small quantity of steam containing acid gases {S37} is mixed with the water to eliminate the last traces of dissolved oxygen and lower the pH of the water in order to

prevent precipitation in the distribution system. The following reaction takes place.<sup>[7]</sup>

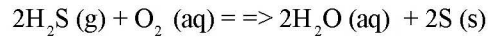

Small quantities of H<sub>2</sub>S ensure the dissolved oxygen that could get into the storage tanks is eliminated. The H<sub>2</sub>S also gives the water the “good smell” for which the water from the water supply system in Reykjavik is known today.

### THE VMGSIM SYSTEM<sup>[8]</sup>

The VMGSim system is a modern interactive process simulation system. One of the partners of VMG (Virtual Materials Group) founded Hyprotech and another created and wrote most of HYSIM. As a general policy, VMGSim is provided to universities free of charge when used for academic purposes.

The system uses Microsoft Visio for the graphical input engine. A menu is provided that allows the user to drag streams and unit operations onto a graphical screen to build a complex system. The system uses the interactive calculation principles of nonsequential unit operation calculations with partial data flow. It is considered to be the fastest approach developed for creating and evaluating process models. Equilibrium stream calculations are carried out as pressure-enthalpy flashes.

The physical property system has been carefully crafted and evaluated to allow the user to have confidence in it. A simple click of the mouse will allow the user to evaluate different physical properties for his/her simulation. Similarly, different units (SI, Field, etc) can be implemented with a simple click of the mouse. Custom models can be created using Excel (VBA).

Vapor Fraction	0.3527
Temperature (Deg C)	189.2
Pressure (kPa)	1235
Flow (kg/s)	326
Enthalpy (kJ/kg)	1500
Water (kg/s)	325.56
Hydrogen Sulfide (kg/s)	0.1495
Carbon Dioxide (kg/s)	0.2875
Oxygen (kg/s)	0
Sulfur (kg/s)	0

Vapor Fraction	0
Temperature (Deg C)	5
Pressure (kPa)	101.33
Flow (kg/s)	1129
Enthalpy (kJ/kg)	21.1
Water (kg/s)	1128.985
Hydrogen Sulfide (kg/s)	0
Carbon Dioxide (kg/s)	9.889 <sup>E-04</sup>
Oxygen (kg/s)	0.0144416
Sulfur (kg/s)	0

<b>Pump Pressure</b>		
	Specified Rise (Δ P - kPa)	Specified Efficiency %
P1	82.33	85
P2	150	80
P3	150	75
P4	75	75
<b>Heat Exchangers</b>		
	Specified Drop Tube (ΔP - kPa)	Specified Drop Shell (ΔP-kPa)
HX1	30	1
HX2	30	20
HX3	30	20
<b>Valves</b>		
	Specified Drop (Δ P - kPa)	
V1 (Mist Eliminator)	35	
V2 to V9	68.94	

TABLE 4 Expander {Ex1}, Condenser {Hx1} and {Hx3}	
<b>Expander</b>	
ΔP drop kPa (specified)	1180
Energy MWe (specified)	60
Adiabatic Efficiency % (calculated)	82.45
<b>Condenser (Hx1)</b>	
Tube side Temperature Rise (specified) <sup>[14]</sup>	50
<b>Heat Exchanger (Hx3)</b>	
Shell Side Temperature Rise (specified) <sup>[14]</sup>	96.9

POLYMATH Report Nonlinear Equations				
Calculated values of NLE variables				
	Variable	Value	f(x)	Initial Guess
1	x1	2159.089	0	4338.9
2	x2	32.52249	0	32.52
3	x3	0.0052474	0	0.009
4	x4	2.552E+06	0	2.552E+06
5	x5	2.5524	2.193E-15	4.53
6	x6	5.431066	0	9.31
7	x7	2.55E+06	0	2.548E+06
8	x8	0.1275113	8.882E-16	0.13

Nonlinear equations	
1	$f(x1) = x4 + x5 + x6 - \text{TotS28} = 0$
2	$f(x3) = x5 / (x4 + x5 + x6) - \text{H2SinS28} = 0$
3	$f(x2) = x8 / (x7 + x8) - \text{O2inS26} = 0$
4	$f(x8) = \text{CO2inS4} * x3 - x6 = 0$
5	$f(x7) = \text{WatinS4} * x3 / 18.016 + x7 / 18.016 + x8 / 16 - x4 / 18.016 = 0$
6	$f(x6) = \text{H2SinS4} * x3 / 34.06 - x8 / 16 - x5 / 34.06 = 0$
7	$f(x5) = \text{O2inS24} - x2 - x8 = 0$
8	$f(x4) = \text{WatinS24} - x1 - x7 = 0$

Explicit equations	
1	$\text{WatinS24} = 2552384.23$
2	$\text{H2SinS28} = 1\text{E-}6$
3	$\text{TotS28} = 2552400.$
4	$\text{O2inS26} = 50\text{E-}9$
5	$\text{H2SinS4} = 538.14$
6	$\text{O2inS24} = 32.65$
7	$\text{WatinS4} = 412914.84$
8	$\text{CO2inS4} = 1035$

# x1 = Mass Water in S25
# x2 = Mass Oxygen in S25
# x3 = Fraction of S4 to reactor
# x4 = Mass Water in S28
# x5 = Mass H2S in S28
# x6 = Mass CO2 in S28
# x7 = Mass Water in S26
# x8 = Mass O2 in S26

Figure 3. Equations to determine deaerator performance.

Overall the system is very flexible and easy to learn and use. It allows very rapid evaluation and optimization of different cases.

## PLANT SIMULATION

VMGSim is used to simulate the plant and match the data given in Figure 1. Steam Table is selected as the physical property system. The components in the simulation are:

1. Water
2. Hydrogen Sulfide
3. Carbon Dioxide
4. Oxygen
5. Sulfur

Figure 2 (p. 134) is the VMGSim flow sheet depiction of the process

There are two feed streams to the plant. In the first, geothermal fluid {S1} contains water, H<sub>2</sub>S, and CO<sub>2</sub>. Table 1 (p. 135) gives the stream composition based on the values of H<sub>2</sub>S and CO<sub>2</sub> (CO<sub>2</sub> 2500 ppm, H<sub>2</sub>S 1300 ppm) in the high-pressure steam {S2}.<sup>[9]</sup> The VMGSim system is used to determine (by iteration) the values of the temperature and pressure of {S1} from the composition of the high pressure steam, the enthalpy and vapor fraction (=115/326) of {S1} specified in Figure 1.

The cold water (Table 2, p. 135) at 1 atm and 5 °C is assumed saturated with oxygen and carbon dioxide. Values of Henry's Law constants (H) are taken from Perry:<sup>[10]</sup>

$H(\text{O}_2) = 29100 \text{ atm/mole fraction (air 20.94\% oxygen)}$

$H(\text{CO}_2) = 878 \text{ atm/mole fraction (air 0.0314\% carbon dioxide)}$

where partial pressure(atm) = H x (mole fraction)

The pressure drops throughout the system are generally not specified in Figure 1 (an exception is the pressure drop across the turbine: 12 bara – 0.2 bara). As a result, literature suggestions<sup>[11, 12]</sup> for pressure drops in the valves and heat exchangers and pressure rises in the pumps (arbitrary) are used as shown in Table 3 (p. 135). Exit streams are assumed to be at about atmospheric pressure. The mist eliminator is simulated as a valve {V1}.

The steam turbine {Ex1} is simulated by an expander, and the electrical energy (MWe) is specified as 60 MW. The condenser is simulated



as a heat exchanger ({Hx1}) and a separator that purges the noncondensable gases (Table 4) .

VMGSim does not have a model of a vacuum deaerator.<sup>[6]</sup> It is simulated, however, with a mixer {M4} and a Component Splitter {CSP1} . A determination is made<sup>[13]</sup> to find the amount of water and O<sub>2</sub> that the deaerator is required to purge in order to meet specifications on the exit water content of O<sub>2</sub>

{S26} and the H<sub>2</sub>S content of the water delivered to Reykjavik {S28}. (All CO<sub>2</sub> is assumed to go overhead)

Figure 3 is a set of eight equations (in eight unknowns), but with just three manipulated variables to achieve three specifications.

**Values To Be Determined:**

1. Fraction of high pressure steam that goes to the reac-

<b>TABLE 5</b>										
<b>Calculated Streams Compared to Reference Number 2</b>										
<b>Iceland's Nesjavellir Co-Generation Power Plant</b>										
Stream	Description	Flow kg/s		Temp Deg C		Enthalpy kJ/kg		Pressure kPa		Frac
			Ref [2]		Ref [2]		Ref [2]		Ref [2]	Vapor
S1	Geothermal Fluid	326	326	189.2		1500	1500	1235		0.3527
S2	High Pressure Steam	115.13	115	189.2		2775.36		1235		1
S3	Geothermal Fluid	210.86	211	189.2		803.57		1235		0
S4	High Pressure Steam	115.13		188.2	188	2775.96		1200	1200	1
S5	Low Pressure Steam	114.53	115	60		2251.9		20	20	0.8519
S6	Condensate	112.62		56.3	60	235.74		19		0
S9	Warm Water	667	667	55		230.39		221.33	0	
S11	Warm Water	667	667	86.4	88	361.96		122.89		0
S14	High Pressure Steam	0	0							
S15	Geothermal Fluid	0	0							
S20	Geothermal Fluid	323.48	326	79.9	81	334.65		101.33		0
S21	Cold Water	1129	1129	5		21.1		101.33		0
S28	Warm Water	709	709	81.7	83	342.19		118.45		0
S30	Cold Water	42	42	5		21.3		182.39		0
S35	Cold Water	1087	1087	5		21.29		251.33		0
S38	Warm Water	420	420	55		230.39		152.39		0
S54	Geothermal Fluid	219.86		92.3	92	387.41		1146.06		0

Turbine Output: Ref [2]= 60 MWe, Simulation = 60 MWe ; Thermal MWt: Ref [2] = 127 MWt, Simulation = 123.88 MWt

\*Note: Numbers in bold are those specified in Figure 1

<b>TABLE 6</b>								
<b>Distribution of Noncondensable Gases</b>								
H <sub>2</sub> S			CO <sub>2</sub>			O <sub>2</sub>		
	In	Out		In	Out		In	Out
Stream	kg/h	kg/h	Stream	kg/h	kg/h	Stream	kg/h	kg/h
S1	543.67					S1	51.99	
S20		12.34	S1	1035.09		S25		32.52
S28		2.55	S21	3.56		S32		19.34
S39		528.51	S20		2.75	Reaction		0.13
Reaction		0.27	S25		2.24			
			S28		5.43			
			S38		1.32			
			S39		1026.91			
<b>Sum</b>	<b>543.67</b>	<b>543.67</b>	<b>Sum</b>	<b>1038.65</b>	<b>1038.65</b>	<b>Sum</b>	<b>51.99</b>	<b>51.99</b>

tor in separator {SP4}

2. The amount of water purged in the deaerator {S25}
3. The amount O<sub>2</sub> purged in the deaerator {S25}.

It is assumed all the CO<sub>2</sub> will be purged.

### Specifications

1. The ppb of O<sub>2</sub> in the liquid leaving the deaerator {S26} – 50 ppb<sup>[5]</sup>
2. The ppm of H<sub>2</sub>S in the exit water {S28} - 1 ppm<sup>[5]</sup>
3. The total flow of the exit water {S28} - 709 kg/s

The results of the computation are used to enter the fractions overhead into the Component Splitter Block in the VMGSim simulation. The exit temperature of the deaerator (81.2 °C) is determined by an enthalpy balance around the deaerator.

Thermal power (MWt) is calculated based on the flow of heated water {S28} and its temperature above 40 °C:

$$\begin{aligned} \text{MWt} &= \text{mass flow of heated water} \times \text{heat capacity} \times (\text{Output Temperature} - 40) \\ &= 123.88 \end{aligned}$$

Table 5 (p. 137) gives the results of the simulation. Numbers in bold are those taken from Figure 1. Other values are results of the simulation.

### DISCUSSION OF THE SIMULATION

As shown in Table 5 the VMGSim simulation matches the indicated conditions<sup>[2]</sup> reasonably well. Two important factors, however, impact the comparison of the simulation and the data of Figure 1.

1. *The plant data of Figure 1 does not indicate any venting from the condenser {Sep2} or specify the amount of high pressure steam in stream {S37}. The simulation calculates both {S37} and {S39}.*
2. *The plant data of Figure 1 does not indicate any venting from the deaerator. The deaerator vents both water and noncondensable gases.*

Small changes in the flow to the expander cause considerable changes in downstream streams {S5}, {S6}, and {S20}. Similarly, small changes in the concentration of H<sub>2</sub>S in the heated water {S28} greatly affect the amount of water purged in the deaerator.

The deaerator design is based on data suggested by an author<sup>[5]</sup> other than Ballzus.<sup>[2]</sup>

The distribution of the noncondensable gases was not addressed in Figure 1 but is discussed by Gislason.<sup>[14]</sup> Table 6 (p. 137) lists the distribution in this simulation. A comparison with Gislason is difficult as he lumps the flows of H<sub>2</sub>S and CO<sub>2</sub> together and indicates different amounts of the noncondensable gases in the entering streams ( {S1} and {S21} ) than used in this study. Also, Gislason does not account for O<sub>2</sub>.

### CONCLUSIONS

Study of Iceland's Nesjavellir Power Plant appears to be well suited for classroom instruction and inclusion in undergraduate energy courses.<sup>[15]</sup> Such a study illustrates both the advantages of geothermal energy as well as indicating some of its limitations in terms of the suitability and source of geothermal fluids.

Carrying out a simulation draws attention to a variety of energy tradeoff issues, material balance questions, physical property estimates, equipment design selection, water chemistry, and environmental control. Interest in geothermal energy generated by this study can be pursued by searching (e.g., on the Internet) for other ways of using this source of energy.<sup>[16]</sup>

### ACKNOWLEDGMENT

The author would like to thank Gerald Jacobs of Virtual Materials Group for making the VMGSim system available to the author to conduct this study.

### REFERENCES

1. Gunnlaugsson, E., A. Ragnarsson, and V. Stefannson, "Geothermal Energy in Iceland," International Symposium in Izmir, Turkey 4-5 (October 2001)
2. Ballzus, C., H. Frimannson, G. Gunnarsson, and I. Hrolfsson, "The Geothermal Power Plant at Nesjavellir, Iceland," Proceedings World Geothermal Congress 2000 Kyushu – Tohoku, Japan, May 28 (June 10, 2000)
3. Reykjavik Energy, Nesjavellir Power Plant
4. "Geothermal Resources in Iceland," <<http://www.energy.rochester.edu/is/reyk/resources.htm>>
5. "How the Plant Works," <<http://www.energy.rochester.edu/is/reyk/works.htm>>
6. <<http://www.filter.ee/site/doc/bros/2/75.pdf>>
7. "Microscale Gas Chemistry: Experiments with Hydrogen Sulfide," <<http://mattson.creighton.edu/H2S/index.html>>
8. Virtual Materials Group, Inc. Version 3.1.44 (January, 2008) <<http://www.virtualmaterials.com>>
9. Gunnarsson, A., B.S. Steingrimsen, E. Gunnlaugsson, J. Magnusson, and R. Maack, "Nesjavellir Geothermal Co-Generation Power Plant," *Geothermics*, **21**(4), 559 (1992)
10. Perry, J.H., *Chemical Engineers' Handbook*, 3<sup>rd</sup> Ed., 673-674 (1950)
11. <[http://www.pc-education.mcmaster.ca/instrumentation/valve\\_sizing.htm](http://www.pc-education.mcmaster.ca/instrumentation/valve_sizing.htm)>
12. <<http://www.cheresources.com/designexzz.shtml>>
13. <[http://www.polymath\\_software.com/](http://www.polymath_software.com/)>
14. Gislason, G., "Nesjavellir Co-Generation Plant, Iceland. Flow of Geothermal Steam and Non-Condensable Gases," *Proceedings World Geothermal Congress 2000 Kyushu – Tohoku, Japan, May 28 (June 10, 2000)*
15. Edgar, T., "A Course on Energy Technology and Policy," *Chem. Eng. Ed.*, **41**(3), 195 (2007)
16. <<http://www.oramat.com>> □